

<b>Document Title</b>	Specification of SOME/IP Transformer
<b>Document Owner</b>	AUTOSAR
<b>Document Responsibility</b>	AUTOSAR
<b>Document Identification No</b>	660

<b>Document Status</b>	published
<b>Part of AUTOSAR Standard</b>	Classic Platform
<b>Part of Standard Release</b>	R20-11

<b>Document Change History</b>			
<b>Date</b>	<b>Release</b>	<b>Changed by</b>	<b>Description</b>
2020-11-30	R20-11	AUTOSAR Release Management	<ul style="list-style-type: none"> <li>• Added call/response context to Client Server requirements</li> <li>• Constraint added for data type of length field of variable Strings</li> <li>• Added E_E2E Error to Table 7.11: Return Codes</li> <li>• Requirement added in case unavailability of optional member in the received serialized byte stream</li> <li>• Reworked E2E communication protection for methods</li> <li>• sizeOfStringLengthField introduced for the size of the length field for dynamic length strings</li> <li>• sizeOfArrayLengthField introduced for the size of the length field for variable size arrays</li> <li>• Fixed design issues with E2E communication protection for methods</li> <li>• Editorial Changes</li> </ul>

2019-11-28	R19-11	AUTOSAR Release Management	<ul style="list-style-type: none"> <li>• Extended Serialization for Data Structures in SOME/IP with tag/length/value encoding set to valid</li> <li>• Removed *_ACK message types</li> <li>• replaced implementsSOMEIPStringHandling (in class SOMEIPTransformationSignalProps) with implementsLegacyStringSerialization</li> <li>• Minor corrections / clarifications / editorial changes; For details please refer to the ChangeDocumentation</li> <li>• Changed Document Status from Final to published</li> </ul>
2018-10-31	4.4.0	AUTOSAR Release Management	<ul style="list-style-type: none"> <li>• Checking for length of received dynamic length strings</li> <li>• Extended Serialization for Data Structures in SOME/IP with tag/length/value encoding</li> <li>• Minor corrections / clarifications / editorial changes; For details please refer to the ChangeDocumentation</li> </ul>
2017-12-08	4.3.1	AUTOSAR Release Management	<ul style="list-style-type: none"> <li>• Bugfixes in serialization of strings and data with variable size</li> <li>• Signatures improved</li> <li>• Minor corrections / clarifications / editorial changes; For details please refer to the ChangeDocumentation</li> </ul>
2016-11-30	4.3.0	AUTOSAR Release Management	<ul style="list-style-type: none"> <li>• Sizes of length fields can be configured independently from each other</li> <li>• Support of union data types</li> <li>• Minor corrections / clarifications / editorial changes; For details please refer to the ChangeDocumentation</li> </ul>

2015-07-31	4.2.2	AUTOSAR Release Management	<ul style="list-style-type: none"> <li>• Size of length fields is configurable</li> <li>• External trigger events are communciated as fire-and-forget methods</li> <li>• Autonomous error reactions of SOME/IP transformer</li> <li>• Minor corrections / clarifications / editorial changes; For details please refer to the ChangeDocumentation</li> </ul>
2014-10-31	4.2.1	AUTOSAR Release Management	Initial Release

## Disclaimer

### Disclaimer

This work (specification and/or software implementation) and the material contained in it, as released by AUTOSAR, is for the purpose of information only. AUTOSAR and the companies that have contributed to it shall not be liable for any use of the work.

The material contained in this work is protected by copyright and other types of intellectual property rights. The commercial exploitation of the material contained in this work requires a license to such intellectual property rights.

This work may be utilized or reproduced without any modification, in any form or by any means, for informational purposes only. For any other purpose, no part of the work may be utilized or reproduced, in any form or by any means, without permission in writing from the publisher.

The work has been developed for automotive applications only. It has neither been developed, nor tested for non-automotive applications.

The word AUTOSAR and the AUTOSAR logo are registered trademarks.

## Table of Contents

1	Introduction and functional overview	7
2	Acronyms and Abbreviations	8
3	Related documentation	9
3.1	Input documents	9
3.2	Related standards and norms	10
3.3	Related specification	10
4	Constraints and assumptions	11
4.1	Limitations	11
4.2	Applicability to car domains	11
5	Dependencies to other modules	12
5.1	File structure	12
5.1.1	Code file structure	12
5.1.2	Header file structure	12
6	Requirements Tracing	13
7	Functional specification	19
7.1	Definition of Identifiers	23
7.2	Specification of the SOME/IP on-wire format	23
7.2.1	Message Length Limitations	24
7.2.2	Endianness	24
7.2.3	Header	24
7.2.3.1	Message ID [32 bit]	25
7.2.3.2	Length [32 bit]	26
7.2.3.3	Request ID [32 bit]	26
7.2.3.4	Protocol Version [8 bit]	27
7.2.3.5	Interface Version [8 bit]	27
7.2.3.6	Message Type [8 bit]	27
7.2.3.7	Return Code [8 bit]	28
7.2.3.8	Payload [variable size]	29
7.2.4	Serialization of Parameters and Data Structures	29
7.2.4.1	Basic Datatypes	30
7.2.4.2	Structured Datatypes (structs)	31
7.2.4.3	Structured Datatypes and Arguments with Identifier and optional Members	33
7.2.4.4	Strings	38
7.2.4.5	Arrays (fixed length)	43
7.2.4.6	Optional Parameters / Optional Elements	46
7.2.4.7	Dynamic Length Arrays / Variable Size Arrays	46
7.2.4.8	Bitfield	49
7.2.4.9	Union / Variant	49

7.3	Protocol specification . . . . .	52
7.3.1	Client/Server Communication . . . . .	52
7.3.2	Sender/Receiver Communication . . . . .	55
7.3.3	Unqueued External Trigger Events . . . . .	56
7.3.4	Error Handling . . . . .	57
7.3.4.1	Return Code . . . . .	57
7.3.4.2	Communication Errors and Handling of Communication Errors . . . . .	58
7.4	Reserved and special identifiers for SOME/IP and SOME/IP-SD. . . . .	60
7.5	Error Classification . . . . .	62
7.5.1	Development Errors . . . . .	62
7.5.2	Runtime Errors . . . . .	62
7.5.3	Transient Faults . . . . .	62
7.5.4	Production Errors . . . . .	62
7.5.5	Extended Production Errors . . . . .	63
8	API specification . . . . .	64
8.1	Imported types . . . . .	64
8.2	Type definitions . . . . .	64
8.3	Function definitions . . . . .	64
8.3.1	SomelpXf_ExtractProtocolHeaderFields . . . . .	64
8.3.2	SomelpXf_<transformerId> . . . . .	66
8.3.3	SomelpXf_Inv_<transformerId> . . . . .	71
8.3.4	SomelpXf_Init . . . . .	75
8.3.5	SomelpXf_DelInit . . . . .	76
8.3.6	SomelpXf_GetVersionInfo . . . . .	76
8.4	Callback notifications . . . . .	76
8.5	Scheduled functions . . . . .	77
8.6	Expected interfaces . . . . .	77
9	Sequence diagrams . . . . .	78
10	Configuration specification . . . . .	79
A	Referenced Meta Classes . . . . .	80
B	Features of SOME/IP not supported by AUTOSAR SOME/IP transformer . . . . .	102
C	Examples . . . . .	103
C.1	Serialization of a Client/Server Operation . . . . .	103
C.1.1	Client . . . . .	104
C.1.2	Server . . . . .	106

# 1 Introduction and functional overview

This document specifies the **Scalable service-Oriented MiddlewarE over IP (SOME/IP) Transformer**. This is a transformer which linearizes data with the SOME/IP on-the-wire format and specifies an automotive/embedded mechanism for Client/Server communication.

The only valid abbreviation is SOME/IP. Other abbreviations (e.g. Some/IP) are wrong and shall not be used.

The basic motivation to specify "yet another Client/Server and Sender/Receiver mechanism" instead of using an existing infrastructure/technology is the goal to have a technology that:

- Fulfills the hard requirements regarding resource consumption in an embedded world
- Is compatible through as many use-cases and communication partners as possible
- Provides the features required by automotive use-cases
- Is scalable from tiny to large platforms
- Can be implemented on different operating system (i.e. AUTOSAR, GENIVI, and OSEK) and even embedded devices without operating system

## 2 Acronyms and Abbreviations

The glossary below includes acronyms and abbreviations relevant to the SOME/IP Transformer that are not included in the [1, AUTOSAR glossary].

Abbreviation / Acronym:	Description:
Client-Service-Instance-Entry	The configuration and required data of a service instance another ECU offers shall be called Client-Service-Instance-Entry at the ECU using this service (Client).
Field	a field represents a status and thus has a valid value at all times on which getter, setter and notifier act upon.
Finding a service instance	to send a SOME/IP-SD message in order to find a needed service instance.
Getter	a Request/Response call that allows read access to a field.
Method	a method, procedure, function, or subroutine that is called/invoked
Notifier	sends out event message with a new value on change of the value of the field.
Request	a message of the client to the server invoking a method
Response	a message of the server to the client transporting results of a method invocation
SD	Service Discovery (see[2])
Service	a logical combination of zero or more methods, zero or more events, and zero or more fields (empty service is allowed, e.g. for announcing non-SOME/IP services in SOME/IP-SD)
Service Instance	software implementation of the service interface, which can exist more than once in the vehicle and more than once on an ECU
Service Interface	the formal specification of the service including its methods, events, and fields
Setter	a Request/Response call that allows write access to a field.
SOME/IP	Scalable service-Oriented MiddlewarE over IP



## 3 Related documentation

### 3.1 Input documents

### References

- [1] Glossary  
AUTOSAR\_TR\_Glossary
- [2] Specification of Service Discovery  
AUTOSAR\_SWS\_ServiceDiscovery
- [3] General Specification of Transformers  
AUTOSAR\_ASWS\_TransformerGeneral
- [4] Specification of Socket Adaptor  
AUTOSAR\_SWS\_SocketAdaptor
- [5] Specification of RTE Software  
AUTOSAR\_SWS\_RTE
- [6] Requirements on AUTOSAR Features  
AUTOSAR\_RS\_Features
- [7] Specification of Platform Types  
AUTOSAR\_SWS\_PlatformTypes
- [8] Software Component Template  
AUTOSAR\_TPS\_SoftwareComponentTemplate
- [9] System Template  
AUTOSAR\_TPS\_SystemTemplate
- [10] Requirements on Transformer  
AUTOSAR\_SRS\_Transformer
- [11] UTF-8, a transformation format of ISO 10646  
<http://www.ietf.org/rfc/rfc3629.txt>
- [12] UTF-16, an encoding of ISO 10646  
<http://www.ietf.org/rfc/rfc2781.txt>
- [13] General Specification of Basic Software Modules  
AUTOSAR\_SWS\_BSWGeneral
- [14] General Requirements on Basic Software Modules  
AUTOSAR\_SRS\_BSWGeneral

### **3.2 Related standards and norms**

Not applicable.

### **3.3 Related specification**

AUTOSAR provides a General Specification on Transformers [3, ASWS Transformer General], which is also valid for SOME/IP Transformer.

Thus, the specification SWS Transformer General shall be considered as additional and required specification for SOME/IP Transformer.

## 4 Constraints and assumptions

### 4.1 Limitations

For the SOME/IP Transformer all general transformer limitations (see [3, ASWS Transformer General]) apply.

The SOME/IP transformer doesn't implement the whole SOME/IP protocol:

- a part is implemented by [2, SWS Service Discovery]
- a part is implemented by [4, SWS Socket Adaptor]
- a part is currently not implemented in AUTOSAR. This is documented in Appendix B

**[SWS\_SomeIpXf\_CONSTR\_0001]** [In accordance with [SWS\_SomeIpXf\_00245],  $2^{(8 * \text{sizeof}(\text{data type of length field}))}$  shall be larger than the number of elements given by the size indicator multiplied by the size in bytes of each element (i.e., 1 for UTF-8 and 2 for UTF-16) and increased by the size in bytes required by the BOM.] ([SRS\\_Xfrm\\_00101](#))

### 4.2 Applicability to car domains

The SOME/IP Transformer can be used for all domain applications when SOME/IP Sender/Receiver or Client/Server communication is used.

## 5 Dependencies to other modules

The AUTOSAR RTE [5, SWS RTE] has to exist to execute the transformer.

### 5.1 File structure

#### 5.1.1 Code file structure

The source code file structure is defined in the [3, ASWS Transformer General].

#### 5.1.2 Header file structure

**[SWS\_SomeIpXf\_00136]** [The header file `SomeIpXf[_<Ie>].h` shall be the main include file for the SOME/IP transformer and include `TransformerTypes.h` and its Module Interlink Header file `SchM_<bsnp>[_<vi>_<ai>].h`.

where

<Ie> is the optional implementation specific file name extension according [SWS\_BSW\_00103],

<bsnp> is the BSW Scheduler Name Prefix according [SWS\_Rte\_07593] and [SWS\_Rte\_07594],

<vi> is the `vendorId` of the BSW module and

<ai> is the `vendorApiInfix` of the BSW module. | ([SRS\\_BSW\\_00346](#))

The file `TransformerTypes.h` contains the general transformer data types.

## 6 Requirements Tracing

The following table references the features specified in [6] and links to the fulfillments of these.

Feature	Description	Satisfied by
[SRS_BSW_00159]	All modules of the AUTOSAR Basic Software shall support a tool based configuration	[SWS_SomelpXf_00185]
[SRS_BSW_00337]	Classification of development errors	[SWS_SomelpXf_00184]
[SRS_BSW_00346]	All AUTOSAR Basic Software Modules shall provide at least a basic set of module files	[SWS_SomelpXf_00136]
[SRS_BSW_00404]	BSW Modules shall support post-build configuration	[SWS_SomelpXf_00183]
[SRS_BSW_00407]	Each BSW module shall provide a function to read out the version information of a dedicated module implementation	[SWS_SomelpXf_00180] [SWS_SomelpXf_00181] [SWS_SomelpXf_00182]
[SRS_BSW_00411]	All AUTOSAR Basic Software Modules shall apply a naming rule for enabling/disabling the existence of the API	[SWS_SomelpXf_00180] [SWS_SomelpXf_00181] [SWS_SomelpXf_00182]
[SRS_BSW_00441]	Naming convention for type, macro and function	[SWS_SomelpXf_00183]
[SRS_Xfrm_00001]	A transformer shall work on data given by the Rte	[SWS_SomelpXf_00264] [SWS_SomelpXf_00265] [SWS_SomelpXf_00266]

[SRS_Xfrm_00002]	A transformer shall provide fixed interfaces	<a href="#">[SWS_SomelpXf_00206]</a> <a href="#">[SWS_SomelpXf_00207]</a> <a href="#">[SWS_SomelpXf_00208]</a> <a href="#">[SWS_SomelpXf_00209]</a> <a href="#">[SWS_SomelpXf_00210]</a> <a href="#">[SWS_SomelpXf_00211]</a> <a href="#">[SWS_SomelpXf_00296]</a> <a href="#">[SWS_SomelpXf_00297]</a> <a href="#">[SWS_SomelpXf_00298]</a> <a href="#">[SWS_SomelpXf_00299]</a> <a href="#">[SWS_SomelpXf_00301]</a> <a href="#">[SWS_SomelpXf_00302]</a> <a href="#">[SWS_SomelpXf_00303]</a> <a href="#">[SWS_SomelpXf_00304]</a> <a href="#">[SWS_SomelpXf_00305]</a> <a href="#">[SWS_SomelpXf_91001]</a>
[SRS_Xfrm_00004]	A transformer shall support error handling	<a href="#">[SWS_SomelpXf_00264]</a> <a href="#">[SWS_SomelpXf_00265]</a> <a href="#">[SWS_SomelpXf_00266]</a>
[SRS_Xfrm_00008]	A transformer shall specify its output format	<a href="#">[SWS_SomelpXf_00001]</a> <a href="#">[SWS_SomelpXf_00002]</a> <a href="#">[SWS_SomelpXf_00005]</a> <a href="#">[SWS_SomelpXf_00006]</a> <a href="#">[SWS_SomelpXf_00007]</a> <a href="#">[SWS_SomelpXf_00009]</a> <a href="#">[SWS_SomelpXf_00010]</a> <a href="#">[SWS_SomelpXf_00011]</a> <a href="#">[SWS_SomelpXf_00013]</a> <a href="#">[SWS_SomelpXf_00015]</a> <a href="#">[SWS_SomelpXf_00024]</a> <a href="#">[SWS_SomelpXf_00025]</a> <a href="#">[SWS_SomelpXf_00026]</a> <a href="#">[SWS_SomelpXf_00029]</a> <a href="#">[SWS_SomelpXf_00030]</a> <a href="#">[SWS_SomelpXf_00031]</a> <a href="#">[SWS_SomelpXf_00033]</a> <a href="#">[SWS_SomelpXf_00130]</a> <a href="#">[SWS_SomelpXf_00131]</a> <a href="#">[SWS_SomelpXf_00132]</a> <a href="#">[SWS_SomelpXf_00133]</a> <a href="#">[SWS_SomelpXf_00134]</a> <a href="#">[SWS_SomelpXf_00152]</a> <a href="#">[SWS_SomelpXf_00154]</a>

		<p>[SWS_SomelpXf_00155]  [SWS_SomelpXf_00156]  [SWS_SomelpXf_00160]  [SWS_SomelpXf_00161]  [SWS_SomelpXf_00163]  [SWS_SomelpXf_00164]  [SWS_SomelpXf_00165]  [SWS_SomelpXf_00166]  [SWS_SomelpXf_00168]  [SWS_SomelpXf_00172]  [SWS_SomelpXf_00212]  [SWS_SomelpXf_00213]  [SWS_SomelpXf_00234]  [SWS_SomelpXf_00235]  [SWS_SomelpXf_00236]  [SWS_SomelpXf_00237]  [SWS_SomelpXf_00238]</p>
<p>[SRS_Xfrm_00101]</p>	<p>The SOME/IP Transformer shall define the serialization of atomic and structured data elements into linear arrays</p>	<p>[SWS_SomelpXf_00016]  [SWS_SomelpXf_00017]  [SWS_SomelpXf_00034]  [SWS_SomelpXf_00036]  [SWS_SomelpXf_00037]  [SWS_SomelpXf_00042]  [SWS_SomelpXf_00053]  [SWS_SomelpXf_00054]  [SWS_SomelpXf_00055]  [SWS_SomelpXf_00056]  [SWS_SomelpXf_00057]  [SWS_SomelpXf_00058]  [SWS_SomelpXf_00059]  [SWS_SomelpXf_00060]  [SWS_SomelpXf_00069]  [SWS_SomelpXf_00070]  [SWS_SomelpXf_00072]  [SWS_SomelpXf_00076]  [SWS_SomelpXf_00088]  [SWS_SomelpXf_00098]  [SWS_SomelpXf_00099]  [SWS_SomelpXf_00151]  [SWS_SomelpXf_00169]  [SWS_SomelpXf_00216]</p>

		[SWS_SomelpXf_00217] [SWS_SomelpXf_00218] [SWS_SomelpXf_00219] [SWS_SomelpXf_00220] [SWS_SomelpXf_00221] [SWS_SomelpXf_00222] [SWS_SomelpXf_00223] [SWS_SomelpXf_00224] [SWS_SomelpXf_00225] [SWS_SomelpXf_00226] [SWS_SomelpXf_00227] [SWS_SomelpXf_00234] [SWS_SomelpXf_00235] [SWS_SomelpXf_00236] [SWS_SomelpXf_00237] [SWS_SomelpXf_00238] [SWS_SomelpXf_00239] [SWS_SomelpXf_00240] [SWS_SomelpXf_00241] [SWS_SomelpXf_00242] [SWS_SomelpXf_00243] [SWS_SomelpXf_00244] [SWS_SomelpXf_00245] [SWS_SomelpXf_00246] [SWS_SomelpXf_00247] [SWS_SomelpXf_00248] [SWS_SomelpXf_00249] [SWS_SomelpXf_00250] [SWS_SomelpXf_00251] [SWS_SomelpXf_00252] [SWS_SomelpXf_00253] [SWS_SomelpXf_00254] [SWS_SomelpXf_00256] [SWS_SomelpXf_00257] [SWS_SomelpXf_00258] [SWS_SomelpXf_00259] [SWS_SomelpXf_00260] [SWS_SomelpXf_00262] [SWS_SomelpXf_00263] [SWS_SomelpXf_CONSTR_0001]
--	--	--



<p>[SRS_Xfrm_00102]</p>	<p>The SOME/IP Transformer shall define a protocol for inter-ECU Client/Server communication</p>	<p>[SWS_SomelpXf_00106] [SWS_SomelpXf_00107] [SWS_SomelpXf_00108] [SWS_SomelpXf_00111] [SWS_SomelpXf_00112] [SWS_SomelpXf_00113] [SWS_SomelpXf_00115] [SWS_SomelpXf_00120] [SWS_SomelpXf_00121] [SWS_SomelpXf_00170] [SWS_SomelpXf_00176] [SWS_SomelpXf_00200] [SWS_SomelpXf_00201] [SWS_SomelpXf_00202] [SWS_SomelpXf_00204] [SWS_SomelpXf_00205]</p>
<p>[SRS_Xfrm_00103]</p>	<p>The SOME/IP Transformer shall support exception notification of applications</p>	<p>[SWS_SomelpXf_00111]</p>
<p>[SRS_Xfrm_00105]</p>	<p>The SOME/IP Transformer shall support autonomous error reactions on the server side for client/server communication</p>	<p>[SWS_SomelpXf_00203]</p>
<p>[SRS_Xfrm_00106]</p>	<p>The SOME/IP Transformer shall support serialization of extensible data structs and methods</p>	<p>[SWS_SomelpXf_00267] [SWS_SomelpXf_00268] [SWS_SomelpXf_00269] [SWS_SomelpXf_00270] [SWS_SomelpXf_00271] [SWS_SomelpXf_00272] [SWS_SomelpXf_00273] [SWS_SomelpXf_00274] [SWS_SomelpXf_00275] [SWS_SomelpXf_00276] [SWS_SomelpXf_00277] [SWS_SomelpXf_00278] [SWS_SomelpXf_00279] [SWS_SomelpXf_00280] [SWS_SomelpXf_00281] [SWS_SomelpXf_00282] [SWS_SomelpXf_00283] [SWS_SomelpXf_00284] [SWS_SomelpXf_00285] [SWS_SomelpXf_00286] [SWS_SomelpXf_00287] [SWS_SomelpXf_00288] [SWS_SomelpXf_00289] [SWS_SomelpXf_00290]</p>

		<a href="#">[SWS_SomeIpXf_00291]</a> <a href="#">[SWS_SomeIpXf_00292]</a> <a href="#">[SWS_SomeIpXf_00293]</a> <a href="#">[SWS_SomeIpXf_00294]</a> <a href="#">[SWS_SomeIpXf_00295]</a>
--	--	--

## 7 Functional specification

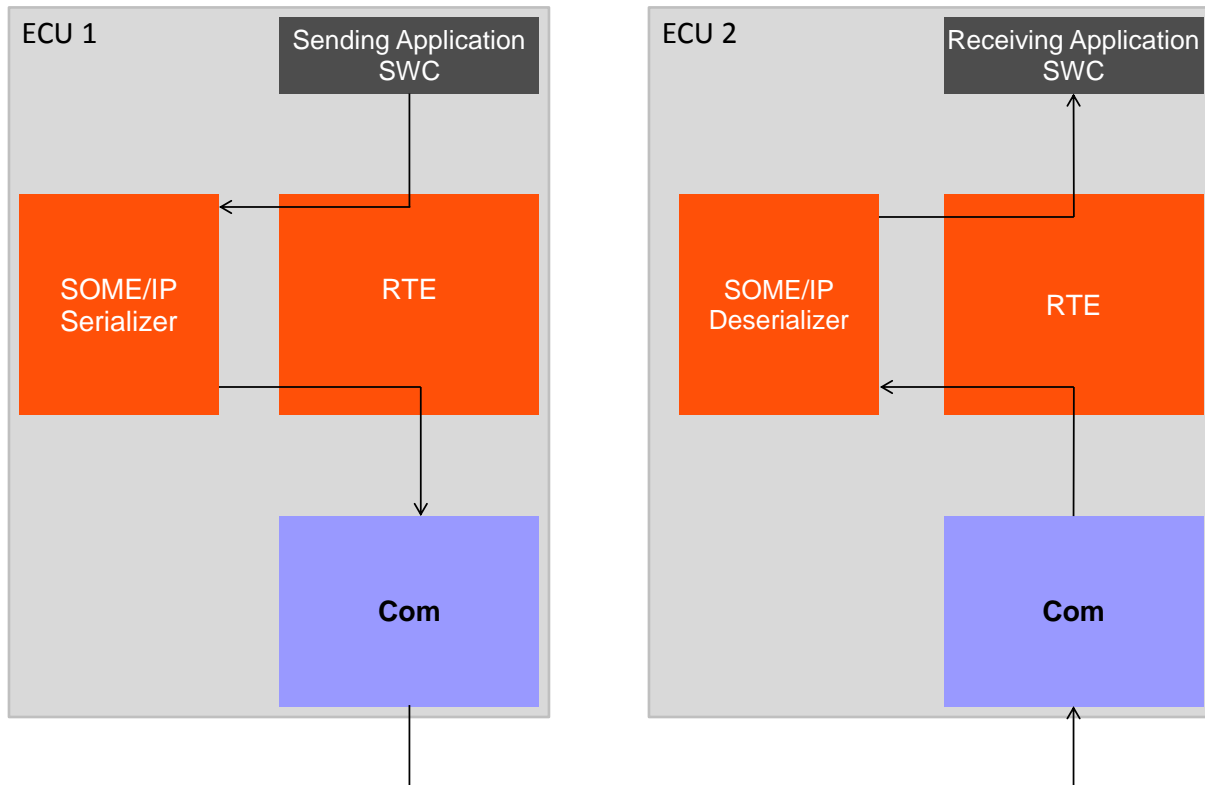

Figure 7.1: Overview of SOME/IP Transformer

When a SWC initiates an inter-ECU communication which is configured to be transformed, the SWC hands the data over to the RTE. The RTE executes the configured transformer chain which contains the SOME/IP Transformer (A transformer chain may contain also other transformers but this is omitted in this overview for simplicity).

The SOME/IP Transformer on the sender side serializes the data of the SWC and brings them into a linear form. The serialized data are sent via the communication stack over the bus to the receiver(s). The RTE of the receiver executes the transformer chain in the reverse order. The SOME/IP transformer of the receiver deserializes the linear data back into the original data structure. These are handed over to the receiving SWC.

From the SWC's point of view it is totally transparent whether data are transformed or not.

The SOME/IP transformer is a transformer of the class **Serializer**. It serializes structured data into a linear form. Therefore it can only be used as the first transformer on the sending side and the last transformer on the receiving side (in execution order). Furthermore it provides the transformer errors specified for this transformer class and supports only out-of-place buffer handling.

The SOME/IP Transformer has no module specific EcuC because its whole configuration is based on the [SOMEIPTransformationDescription](#) and [SOMEIPTransformationISignalProps](#).

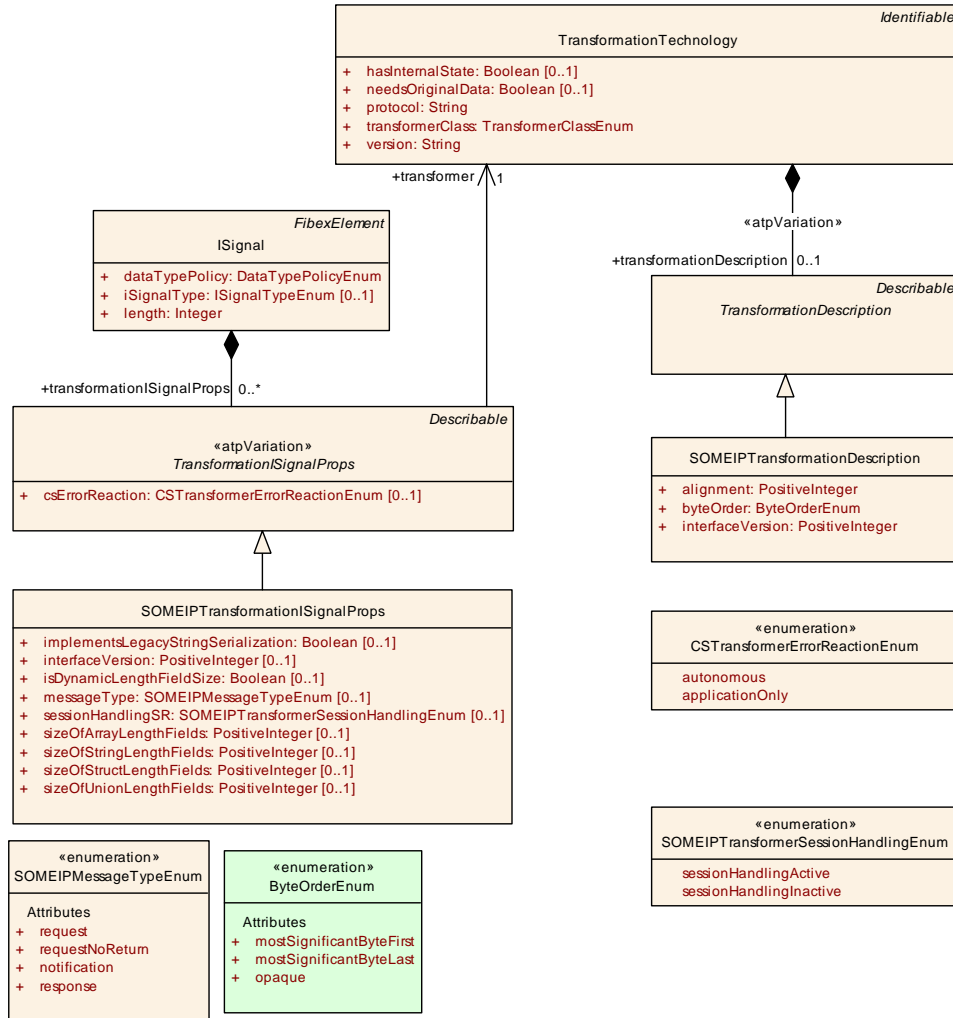

Figure 7.2: SOME/IP specific configuration

<b>Class</b>	<b>SOMEIPTransformationDescription</b>			
<b>Package</b>	M2::AUTOSARTemplates::SystemTemplate::Transformer			
<b>Note</b>	The SOMEIPTransformationDescription is used to specify SOME/IP transformer specific attributes.			
<b>Base</b>	ARObject, Describable, TransformationDescription			
<b>Attribute</b>	<b>Type</b>	<b>Mult.</b>	<b>Kind</b>	<b>Note</b>
alignment	PositiveInteger	1	attr	Defines the padding for alignment purposes that will be added by the SOME/IP transformer after the serialized data of the variable data length data element. The alignment shall be specified in Bits.
byteOrder	ByteOrderEnum	1	attr	Defines which byte order shall be serialized by the SOME/IP transformer
interfaceVersion	PositiveInteger	1	attr	The interface version the SOME/IP transformer shall use.

Table 7.1: SOMEIPTransformationDescription

<b>Class</b>	<<atpVariation>> <b>SOMEIPTransformationISignalProps</b>			
<b>Package</b>	M2::AUTOSARTemplates::SystemTemplate::Transformer			
<b>Note</b>	The class SOMEIPTransformationISignalProps specifies ISignal specific configuration properties for SOME/IP transformer attributes.			
<b>Base</b>	ARObject, Describable, TransformationISignalProps			
<b>Attribute</b>	<b>Type</b>	<b>Mult.</b>	<b>Kind</b>	<b>Note</b>
implements LegacyString Serialization	Boolean	0..1	attr	<p>This attribute indicates that Strings in the SOME/IP message shall NOT be serialized according to the SOME/IP specification for Strings.</p> <p>If this attribute is set to true, BOM and null-termination shall NOT be added in the serialization for Strings in the payload. If this attribute is set to false (or not set) BOM and null-termination shall be added in the serialization for Strings in the payload according to the SOME/IP specification for Strings.</p> <p>NOTE! This attribute is not future safe, and will be removed in an upcoming AUTOSAR release!"</p>
interfaceVersion	PositiveInteger	0..1	attr	The interface version the SOME/IP transformer shall use.
isDynamic LengthFieldSize	Boolean	0..1	attr	This attribute shall be used to determine the wire type in the context of using the TLV encoding.
messageType	<a href="#">SOMEIPMessageType Enum</a>	0..1	attr	The Message Type which shall be placed into the SOME/IP header.
session HandlingSR	<a href="#">SOMEIPTransformer SessionHandlingEnum</a>	0..1	attr	Defines whether the SOME/IP transformer shall use session handling for Sender/Receiver communication.
sizeOfArray LengthFields	PositiveInteger	0..1	attr	The size of all length fields (in Bytes) of fixed-size arrays or dynamic size arrays in the SOME/IP message. This attribute is valid for all available occurrences of fixed-size arrays or dynamic size arrays in the SOME/IP message.
sizeOfString LengthFields	PositiveInteger	0..1	attr	The size of all length fields (in Bytes) of dynamic length strings in the SOME/IP message. This attribute is valid for all available occurrences of strings in the SOME/IP message.
sizeOfStruct LengthFields	PositiveInteger	0..1	attr	The size of all length fields (in Bytes) of structs in the SOME/IP message. This attribute is valid for all available occurrences of structures in the SOME/IP message. For a more fine granular modeling on the level of Data Prototypes the DataPrototypeTransformationProps shall be used.
sizeOfUnion LengthFields	PositiveInteger	0..1	attr	The size of all length fields (in Bytes) of unions in the SOME/IP message. This attribute is valid for all available occurrences of Unions in the SOME/IP message. For a more fine granular modeling on the level of Data Prototypes the DataPrototypeTransformationProps shall be used.
tlvDataId Definition	TlvDataIdDefinitionSet	*	ref	This reference identifies the TlvDataIdDefinitions relevant for the enclosing SOMEIPTransformationISignalProps

**Table 7.2: SOMEIPTransformationISignalProps**

<b>Enumeration</b>	<b>ByteOrderEnum</b>
<b>Package</b>	M2::AUTOSARTemplates::GenericStructure::GeneralTemplateClasses::PrimitiveTypes





<b>Enumeration</b>	<b>ByteOrderEnum</b>
<b>Note</b>	When more than one byte is stored in the memory the order of those bytes may differ depending on the architecture of the processing unit. If the least significant byte is stored at the lowest address, this architecture is called little endian and otherwise it is called big endian.  ByteOrder is very important in case of communication between different PUs or ECUs.
<b>Literal</b>	<b>Description</b>
mostSignificantByte First	Most significant byte shall come at the lowest address (also known as BigEndian or as Motorola-Format) <b>Tags:</b> atp.EnumerationLiteralIndex=0
mostSignificantByte Last	Most significant byte shall come highest address (also known as LittleEndian or as Intel-Format) <b>Tags:</b> atp.EnumerationLiteralIndex=1
opaque	For opaque data endianness conversion has to be configured to Opaque. See AUTOSAR COM Specification for more details. <b>Tags:</b> atp.EnumerationLiteralIndex=2

**Table 7.3: ByteOrderEnum**

<b>Enumeration</b>	<b>SOMEIPMessageTypeEnum</b>
<b>Package</b>	M2::AUTOSARTemplates::SystemTemplate::Transformer
<b>Note</b>	Depending on the style of the communication different message types shall be set in the header of a SOME/IP message.
<b>Literal</b>	<b>Description</b>
notification	A request of a notification expecting no response. <b>Tags:</b> atp.EnumerationLiteralIndex=1
request	A request expecting a response. <b>Tags:</b> atp.EnumerationLiteralIndex=2
requestNoReturn	A fire&forget request. <b>Tags:</b> atp.EnumerationLiteralIndex=3
response	The response message. <b>Tags:</b> atp.EnumerationLiteralIndex=4

**Table 7.4: SOMEIPMessageTypeEnum**

**[SWS\_SomeIpXf\_00151]** [The SOME/IP transformer defined in this document shall be used as a transformer if

- the attribute `protocol` of the `TransformationTechnology` is set to `SOMEIP`
- and the attribute `version` of the `TransformationTechnology` is set to `1`
- and the attribute `transformerClass` of the `TransformationTechnology` is set to `serializer`

] ([SRS\\_Xfrm\\_00101](#))

## 7.1 Definition of Identifiers

**[SWS\_SomelpXf\_00001]** [A service shall be identified using the Service-ID.] ([SRS\\_Xfrm\\_00008](#))

**[SWS\_SomelpXf\_00002]** [Service-IDs shall be of type 16 bit length unsigned integer (uint16).] ([SRS\\_Xfrm\\_00008](#))

The Service-ID of `0xFFFFE` shall be used to encode non-SOME/IP services. See [\[SWS\\_SomelpXf\\_00130\]](#).

**[SWS\_SomelpXf\_00005]** [Different services within the same vehicle shall have different Service-IDs.] ([SRS\\_Xfrm\\_00008](#))

**[SWS\_SomelpXf\_00006]** [A service instance shall be identified using the Service-Instance-ID.] ([SRS\\_Xfrm\\_00008](#))

**[SWS\_SomelpXf\_00007]** [Service-Instance-IDs shall be of type 16 bit length unsigned integer (uint16).] ([SRS\\_Xfrm\\_00008](#))

The Service-Instance-IDs of `0x0000` and `0xFFFF` shall not be used for a service, since `0x0000` is reserved and `0xFFFF` is used to describe all service instances. See [\[SWS\\_SomelpXf\\_00130\]](#).

**[SWS\_SomelpXf\_00009]** [Different service instances within the same vehicle shall have different Service-Instance-IDs.] ([SRS\\_Xfrm\\_00008](#))

### Note:

This means that two different camera services shall have two different ServiceInstance-IDs SI-ID-1 and SI-ID-2. For one AUTOSAR system (that designs a vehicle product line) SI-ID-1 shall be the same for all vehicles. The same is true for SI-ID-2. If considering another AUTOSAR system (that designs another vehicle product line), different IDs may be used but it makes sense to use the same IDs among different AUTOSAR systems for ease in testing and integration.

**[SWS\_SomelpXf\_00010]** [Methods and events shall be identified inside a service using a 16bit Method-ID, which is called Event-ID for events and notifications.] ([SRS\\_Xfrm\\_00008](#))

**[SWS\_SomelpXf\_00011]** [Methods shall use Method-IDs with the highest bit set to 0, while the Method-IDs highest bit shall be set to 1 for events and notifications of fields.] ([SRS\\_Xfrm\\_00008](#))

## 7.2 Specification of the SOME/IP on-wire format

Serialization describes the way data is represented in protocol data units (PDUs) transported over an automotive in-vehicle network.

### 7.2.1 Message Length Limitations

The usage of TCP allows for larger streams of data to transport SOME/IP header and payload. However, current transport protocols for CAN and FlexRay limit messages to 4095 Bytes. When compatibility to those has to be achieved, SOME/IP messages including the SOME/IP header shall not exceed 4095 Bytes.

### 7.2.2 Endianness

**[SWS\_SomIpXf\_00013]** [All headers shall be encoded in network byte order Big Endian (MostSignificantByteFirst) [RFC 791].] ([SRS\\_Xfrm\\_00008](#))

This means that Length and Type fields shall be always in network byte order.

**[SWS\_SomIpXf\_00172]** [The byte order of the parameters inside the payload shall be defined by `byteOrder` of `SOMEIPTransformationDescription`.] ([SRS\\_Xfrm\\_00008](#))

### 7.2.3 Header

**[SWS\_SomIpXf\_00152]** [For interoperability reasons the header layout shall be identical for all implementations of SOME/IP and is described as follows:

1. Message ID (Service ID / Method ID) [32 bit]
2. Length [32 bit]
3. Additional information:
  - (a) Protocol Version [8 bit]
  - (b) Interface Version [8 bit]
  - (c) Message Type [8 bit]
  - (d) Return Code [8 bit]
4. Payload [variable size]

The fields are presented in transmission order; i.e. the fields on the top are transmitted first. In the following sections the different header fields and their usage is being described.] ([SRS\\_Xfrm\\_00008](#))

Note: Layout is also shown in Figure [7.3](#).



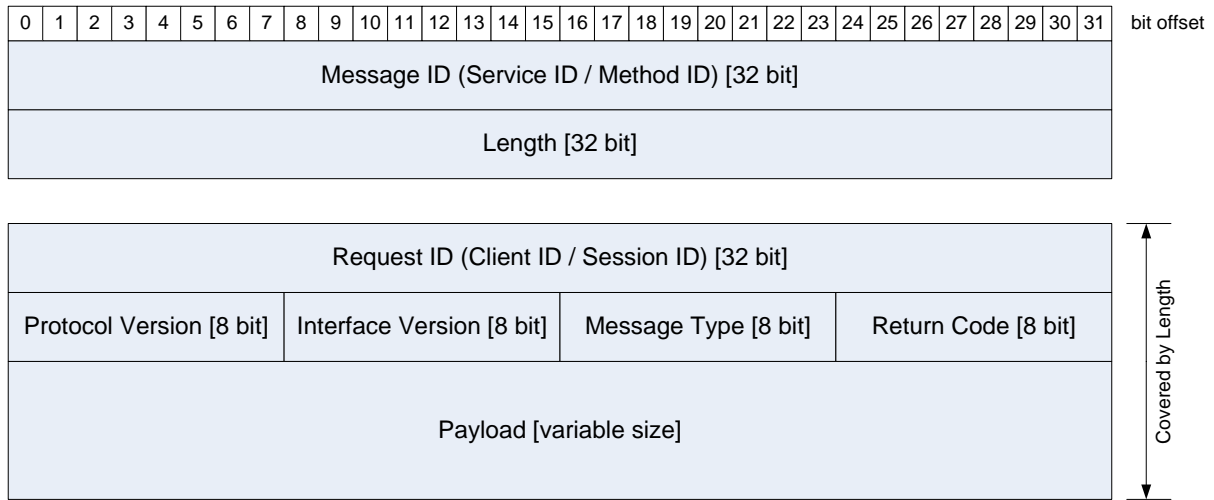

**Figure 7.3: SOME/IP Header Format**

Figure 7.3 shows the **complete** SOME/IP header. The SOME/IP transformer only implements the lower part (all except Message ID and Length).

**[SWS\_SomelpXf\_00015]** [The SOME/IP transformer shall implement all fields of the header except Message ID and Length.] (*SRS\_Xfrm\_00008*)

Rationale:

Message-ID and Length are not covered since this allows the AUTOSAR Socket Adaptor header mode to work.

These are added by other modules in the AUTOSAR BSW. Nonetheless they are contained in Figure 7.3 to show the whole on-wire-format.

### 7.2.3.1 Message ID [32 bit]

The Message ID is a 32 bit identifier that is used to identify the message. The Message ID has to uniquely identify a method or event of a service.

The assignment of the Message ID is up to the user; however, the Message ID has to be unique for the whole system (i.e. the vehicle). The Message ID can be best compared to a CAN ID and should be handled with a comparable process. The next section 7.2.3.1.1 describes how to structure the Message IDs in order to ease the organization of Message IDs.

#### 7.2.3.1.1 Structure of the Message ID

In order to structure the different methods, events, and fields, they are clustered into services. Services have a set of methods, events, and fields as well as a Service ID, which is only used for this service.

An event shall be part of zero to many eventgroups and an eventgroup shall contain zero to many events. A field shall be part of zero to many eventgroups and an eventgroup can contain zero to many fields.

For inter-ECU Client/Server communication calls we structure the ID in  $2^{16}$  services with  $2^{15}$  methods:

Service ID [16 bit]	0 [1 bit]	Method ID [last 15 bits]
---------------------	-----------	--------------------------

where the 0-Bit is the first bit of the 16 bit Method ID.

With 16 bit Service-ID and a 16 bit Method-ID starting with a 0-Bit (15 bit are still left in the Method-ID for real values), this allows for up to 65536 services with up to 32768 methods each.

Since events and notifications are transported using Client/Server communication, the ID space for the events is further structured:

Service ID [16 bit]	1 [1 bit]	Event ID [last 15 bits]
---------------------	-----------	-------------------------

where the 1-Bit is the first bit of the 16 bit Method ID.

This means that up to 32768 events or notifications per service are possible.

### 7.2.3.2 Length [32 bit]

The Length field is 32 bit long and contains the length in Byte of the payload beginning with the Request ID/Client ID until the end of the SOME/IP-message.

### 7.2.3.3 Request ID [32 bit]

**[SWS\_SomeIpXf\_00154]** [The Request ID field shall be 32 bit long.] ([SRS\\_Xfrm\\_00008](#))

The Request ID shall be the unique identifier for the calling client inside the ECU. Its values are chosen by the RTE and handed over to the SOME/IP transformer.

**[SWS\_SomeIpXf\_00024]** [The Request ID shall be constructed of the Client ID and Session ID as shown in Table 7.5.] ([SRS\\_Xfrm\\_00008](#))

Client ID [16 bits]	Session ID [16 bits]
---------------------	----------------------

**Table 7.5: Construction of Request ID**

Both are chosen by RTE and handed over to the transformer as `Rte-Cs_TransactionHandleType`.

**[SWS\_SomelpXf\_00025]** [The `clientId` inside the `Rte-Cs_TransactionHandleType` handed over from RTE shall be used for the value of the Client ID.] ([SRS\\_Xfrm\\_00008](#))

**[SWS\_SomelpXf\_00026]** [The `sequenceCounter` inside the `Rte-Cs_TransactionHandleType` handed over from RTE shall be used for the value of the Session ID.] ([SRS\\_Xfrm\\_00008](#))

For details of `Rte-Cs_TransactionHandleType` see [SWS\_Rte\_08732].

The Request ID allows a client to differentiate multiple calls to the same method. Therefore, the Request ID has to be unique for a single client and server combination only. When generating a response message, the server has to copy the Request ID from the request to the response message. This allows the client to map a response to the issued request even with more than one request outstanding.

Request IDs may be reused as soon as the response arrived or is not expected to arrive anymore (timeout).

#### 7.2.3.4 Protocol Version [8 bit]

**[SWS\_SomelpXf\_00155]** [The Protocol Version field shall be 8 bit long.] ([SRS\\_Xfrm\\_00008](#))

**[SWS\_SomelpXf\_00156]** [The Protocol Version field shall contain the SOME/IP protocol version.] ([SRS\\_Xfrm\\_00008](#))

**[SWS\_SomelpXf\_00029]** [The Protocol Version shall be set to 0x01.] ([SRS\\_Xfrm\\_00008](#))

#### 7.2.3.5 Interface Version [8 bit]

**[SWS\_SomelpXf\_00030]** [The Interface Version field shall be 8 bit long.] ([SRS\\_Xfrm\\_00008](#))

**[SWS\_SomelpXf\_00160]** [The Interface Version field shall contain the Version of the Service Interface.] ([SRS\\_Xfrm\\_00008](#))

Rationale: This is required to catch mismatches in Service definitions and allows debugging tools to identify the Service Interface used, if version is used.

#### 7.2.3.6 Message Type [8 bit]

**[SWS\_SomelpXf\_00161]** [The Message Type field shall be 8 bit long.] ([SRS\\_Xfrm\\_00008](#))

The Message Type field is used to differentiate different types of messages.

**[SWS\_SomelpXf\_00031]** [The Message Type field shall be filled with one of the values of Table 7.6.] ([SRS\\_Xfrm\\_00008](#))

Number	Value	Description
0x00	REQUEST	A request expecting a response (even void)
0x01	REQUEST_NO_RETURN	A fire&forget request
0x02	NOTIFICATION	A request of a notification expecting no response
0x80	RESPONSE	The response message
0x81	ERROR	The response containing an error

**Table 7.6: Message Types**

A regular client request (message type 0x00) is answered by a server response (message type 0x80), when no error occurred. If errors occur an error message (message type 0x81) will be sent.

For updating values through notification a callback interface exists (message type 0x02).

It is possible to send a request that does not have a response message (message type 0x01) to use SOME/IP for AUTOSAR Sender/Receiver communication.

### 7.2.3.7 Return Code [8 bit]

**[SWS\_SomelpXf\_00163]** [The Return Code field shall be 8 bit long.] ([SRS\\_Xfrm\\_00008](#))

**[SWS\_SomelpXf\_00164]** [The Return Code field shall be used to signal whether a request has been successfully processed.] ([SRS\\_Xfrm\\_00008](#))

For simplification of the header layout, every message transports the field Return Code.

The Return Codes are specified in detail in [[SWS\\_SomelpXf\\_00115](#)].

**[SWS\_SomelpXf\_00033]** [Messages of Type REQUEST, REQUEST\_NO\_RETURN, and Notification have to set the Return Code to 0x00 (E\_OK).] ([SRS\\_Xfrm\\_00008](#))

**[SWS\_SomelpXf\_00168]** [The allowed Return Codes for specific message types are specified in Table 7.7.] ([SRS\\_Xfrm\\_00008](#))

Message Type	Allowed Return Codes
REQUEST	N/A, set to 0x00 (E_OK)
REQUEST_NO_RETURN	N/A, set to 0x00 (E_OK)
NOTIFICATION	N/A, set to 0x00 (E_OK)
RESPONSE	See Return Codes in [ <a href="#">SWS_SomelpXf_00115</a> ].

**Table 7.7: Return Codes**

### 7.2.3.8 Payload [variable size]

**[SWS\_SomelpXf\_00165]** [The Payload field shall have variable size.]([SRS\\_Xfrm\\_00008](#))

**[SWS\_SomelpXf\_00166]** [The Payload field shall contain the transported data.]([SRS\\_Xfrm\\_00008](#))

The serialization of the data will be specified in the following section.

## 7.2.4 Serialization of Parameters and Data Structures

**[SWS\_SomelpXf\_00034]** [The serialization shall be based on the [SenderReceiverInterface](#) or [ClientServerInterface](#) of the data.]([SRS\\_Xfrm\\_00101](#))

**[SWS\_SomelpXf\_00169]** [To allow migration the deserialization shall ignore parameters attached to the end of previously known parameter list.]([SRS\\_Xfrm\\_00101](#))

This means: Parameters that were not defined in the [ClientServerInterface](#) or [SenderReceiverInterface](#) used to generate or parameterize the deserialization code at the end of the serialized data will be ignored by the deserialization.

**[SWS\_SomelpXf\_00259]** [After the serialized data of a variable data length [DataPrototype](#) a padding for alignment purposes shall be added for the configured alignment (see [[SWS\\_SomelpXf\\_00260](#)] and [[SWS\\_SomelpXf\\_00262](#)]) if the variable data length [DataPrototype](#) is not the last element in the serialized data stream. This requirement does not apply for the serialization of extensible structs and methods.]([SRS\\_Xfrm\\_00101](#))

Note: See also chapter [7.2.4.3](#).

**[SWS\_SomelpXf\_00260]** [If [SOMEIPTransformationProps.alignment](#) is set for a variable data length data element, the value of [SOMEIPTransformationProps.alignment](#) defines the alignment. This requirement does not apply for the serialization of extensible structs and methods.]([SRS\\_Xfrm\\_00101](#))

Note: See also chapter [7.2.4.3](#).

**[SWS\_SomelpXf\_00262]** [If [SOMEIPTransformationProps.alignment](#) is not set for a variable data length data element, the value of [SOMEIPTransformationDescription.alignment](#) defines the alignment. This requirement does not apply for the serialization of extensible structs and methods.]([SRS\\_Xfrm\\_00101](#))

Note: See also chapter [7.2.4.3](#).

**[SWS\_SomelpXf\_00263]** [After serialized fixed data length data elements, the SOME/IP transformer shall never add automatically a padding for alignment.]([SRS\\_Xfrm\\_00101](#))

Note:

If the following data element shall be aligned, a padding element of according size needs to be explicitly inserted into the [ImplementationDataType](#).

**[SWS\_SomelpXf\_00037]** [Alignment shall always be calculated from start of SOME/IP message.]([SRS\\_Xfrm\\_00101](#))

This attribute defines the memory alignment. The SOME/IP Transformer does not try to automatically align parameters but aligns as specified. The alignment is currently constraint to multiple of 1 Byte to simplify code generators.

SOME/IP payload should be placed in memory so that the SOME/IP payload is suitable aligned. For infotainment ECUs an alignment of 8 Bytes (i.e. 64 bits) should be achieved, for all ECU at least an alignment of 4 Bytes should be achieved. An efficient alignment is highly hardware dependent.

**[SWS\_SomelpXf\_00016]** [If more data than expected are handed over to the SOME/IP transformer during deserialization of data, the unexpected data shall be discarded. The known fraction shall be considered.]([SRS\\_Xfrm\\_00101](#))

**[SWS\_SomelpXf\_00017]** [If less data than expected are handed over to the SOME/IP transformer during deserialization of data, the following shall happen:

- if for the corresponding [ISignal](#) an initial value is specified (in serialized form) use the value to fill the missing elements at the end of the serialized stream.
- if no initial value is available abort deserialization with `E_SER_MALFORMED_MESSAGE`.

]([SRS\\_Xfrm\\_00101](#))

Missing data can only be recognized by comparing the length of received serialized data with the expected length of the data. [\[SWS\\_SomelpXf\\_00017\]](#) enables extensions of data by adding elements to the end and achieve backward compatibility of an ECU with older boardnet layouts that are missing those data.

In the following the serialization of different parameters is specified.

### 7.2.4.1 Basic Datatypes

**[SWS\_SomelpXf\_00036]** [The [SwBaseTypes](#) defined in [\[7\]](#) and according to [\[TPS\\_-STDT\\_00067\]](#) placed in the package `/AUTOSAR_Platform/BaseTypes` (e.g., `/AUTOSAR_Platform/BaseTypes/uint32`) whihc shall be supported for serialization are listed in [Table 7.8.](#)]([SRS\\_Xfrm\\_00101](#))

Type	Description	Size [bit]	Remark
boolean	TRUE/FALSE value	8	FALSE (0), TRUE (1)
uint8	unsigned Integer	8	
uint16	unsigned Integer	16	
uint32	unsigned Integer	32	

uint64	unsigned Integer	64	
sint8	signed Integer	8	
sint16	signed Integer	16	
sint32	signed Integer	32	
sint64	signed Integer	64	
float32	floating point number	32	IEEE 754 binary32 (Single Precision)
float64	floating point number	64	IEEE 754 binary64 (Double Precision)

**Table 7.8: SwBaseTypes supported for serialization**

The Byte Order is specified common for all parameters by `byteOrder` of `SOMEIP-TransformationDescription`. See chapter 7.2.2.

#### 7.2.4.2 Structured Datatypes (structs)

**[SWS\_SomeIpXf\_00042]** [A struct shall be serialized in order of depth-first traversal.] (*SRS\_Xfrm\_00101*)

The transformer doesn't automatically align parameters of a struct.

Insert reserved/padding elements into the AUTOSAR data type if needed for alignment, since the SOME/IP implementation shall not automatically add such padding.

So if for example a struct includes a uint8 and a uint32, they are just written sequentially into the buffer. This means that there is no padding between the uint8 and the first byte of the uint32; therefore, the uint32 might not be aligned. So the system designer has to consider to add padding elements to the data type to achieve the required alignment or set it globally.

Warning about unaligned structs or similar shall not be done in the implementation but only in the tool chain used to generate the implementation.

Messages of legacy busses like CAN and FlexRay are usually not aligned. Warnings can be turned off or be ignored in such cases.

The SOME/IP transformer does not automatically insert dummy/padding elements.

SOME/IP allows to add a length field of 8, 16 or 32 bit in front of structs. The length field of a struct describes the number of bytes of the struct. This allows for extensible structs which allow better migration of interfaces.

**[SWS\_SomeIpXf\_00216]** [If attribute `sizeofStructLengthFields` of `SOMEIP-TransformationISignalProps` is set to a value greater 0, a length field shall be inserted in front of every serialized struct.] (*SRS\_Xfrm\_00101*)

Note:

**[SWS\_SomeIpXf\_00216]** also applies to nested structs which means that additionally

every nested struct has its own length field. Furthermore, in an array of structs where all structs have the same length, the length field is inserted in front of every struct inside the array.

**[SWS\_SomelpXf\_00252]** [If attribute `sizeofStructLengthField` of `SOMEIPTransformationProps` is set to a value greater 0, a length field shall be inserted in front of the serialized struct for which the `SOMEIPTransformationProps` is defined. (See [TPS\_SYST\_02121])] (*SRS\_Xfrm\_00101*)

Note:

[SWS\_SomelpXf\_00252] applies if the length fields of the struct and all nested structs contained within the root struct are configured to different values for the lengths of the length fields via `SOMEIPTransformationProps`.

**[SWS\_SomelpXf\_00217]** [The data type of the length field of the struct and all nested structs within the struct shall be the same and shall be determined by the value of `SOMEIPTransformationISignalProps.sizeOfStructLengthFields` of the serialized `ISignal`:

- `uint8` if `sizeofStructLengthFields` equals 1
- `uint16` if `sizeofStructLengthFields` equals 2
- `uint32` if `sizeofStructLengthFields` equals 4

] (*SRS\_Xfrm\_00101*)

**[SWS\_SomelpXf\_00253]** [If `SOMEIPTransformationProps.sizeOfStructLengthField` is present for a struct the data type for the length field of the struct shall be determined by the value of `SOMEIPTransformationProps.sizeOfStructLengthField`:

- `uint8` if `sizeofStructLengthField` equals 1
- `uint16` if `sizeofStructLengthField` equals 2
- `uint32` if `sizeofStructLengthField` equals 4
- Otherwise [SWS\_SomelpXf\_00217] applies.

] (*SRS\_Xfrm\_00101*)

**[SWS\_SomelpXf\_00218]** [The serializing SOME/IP transformer shall write the size (in bytes) of the serialized struct (without the size of the length field) into the length field of the struct.] (*SRS\_Xfrm\_00101*)

**[SWS\_SomelpXf\_00219]** [If the length is greater than the expected length of a struct (as specified in the data type definition) a deserializing SOME/IP transformer shall only interpret the expected data and skip the unexpected.] (*SRS\_Xfrm\_00101*)

To determine the start of the next expected data following the skipped unexpected part, the SOME/IP transformer can use the supplied length information.



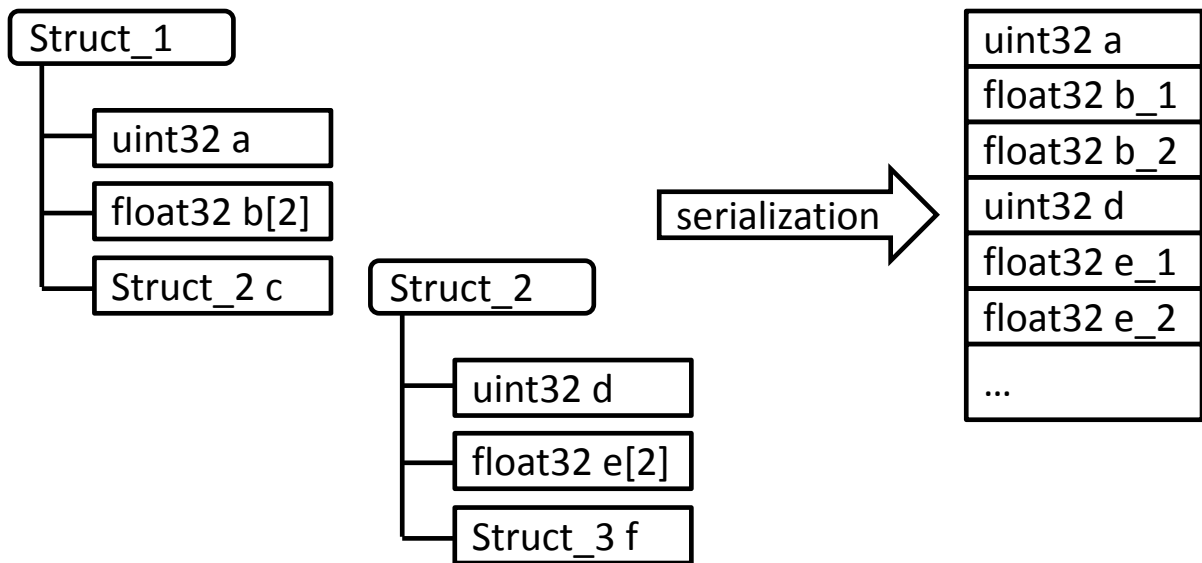

Figure 7.4: Serialization of Structs without Length Fields (Example)

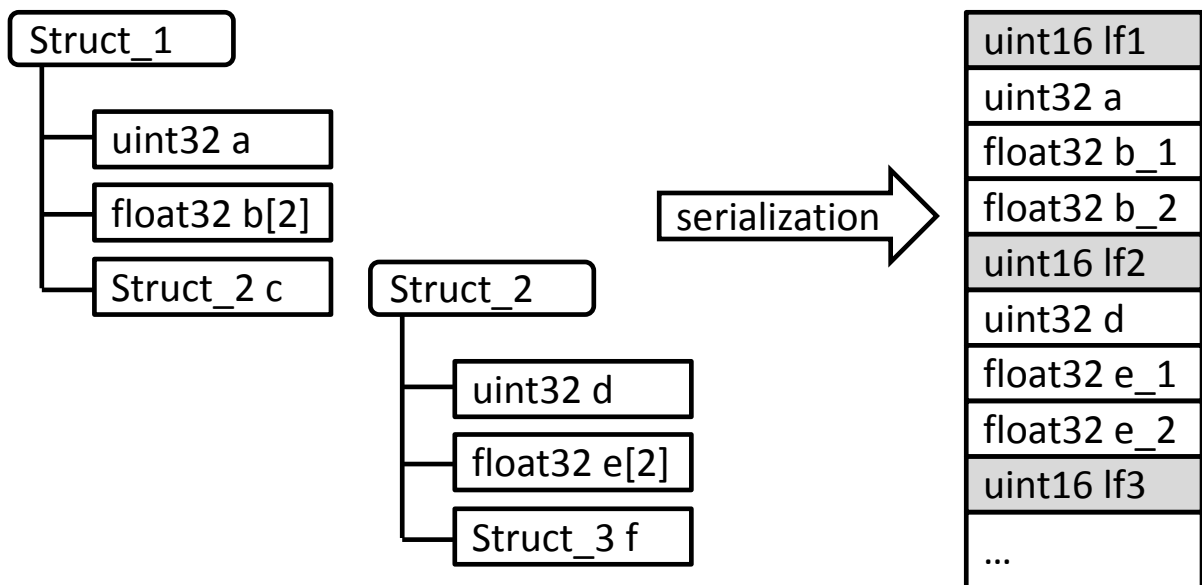

Figure 7.5: Serialization of Structs with Length Fields (Example)

**7.2.4.3 Structured Datatypes and Arguments with Identifier and optional Members**

Please note that the content of this chapter has draft character

To achieve enhanced forward and backward compatibility, an additional Data ID can be added in front of struct members or method arguments. The receiver then can skip unknown members/arguments, i.e. where the Data ID is unknown. New member/s/arguments can be added at arbitrary positions when Data IDs are transferred in the serialized byte stream.

Structs are modeled in the Software Component Template using an `ImplementationDataType` of category `STRUCTURE` and members are represented by `ImplementationDataTypeElements`. Method arguments are represented by `ArgumentDataPrototypes`. Refer to [8] for more details.

The assignment of Data IDs is modeled in the System Template in the context of `SOMEIPTransformationISignalProps`. Refer to [9] for more details.

Moreover, the usage of Data IDs allows describing structs with optional members. To serialize data with optional members, the transformer has to know which optional members are available or not. This is stored in a bitfield which is contained inside the `ImplementationDataType`. This `availabilityBitfield` is realized as array of `uint8`.

Whether an optional member is actually present in the struct or not, must be determined during runtime.

In addition to the Data ID, a wire type encodes the datatype of the following member. Data ID and wire type are encoded in a so-called tag.

**[SWS\_SomeIpXf\_00267]** [The length of a tag shall be two bytes.] (*SRS\_Xfrm\_00106*)

**[SWS\_SomeIpXf\_00268]** [The tag shall consist of

- reserved (Bit 7 of the first byte)
- wire type (Bit 6-4 of the first byte)
- Data ID (Bit 3-0 of the first byte and bit 7-0 of the second byte)

Bit 7 is the highest significant bit of a byte, bit 0 is the lowest significant bit of a byte.] (*SRS\_Xfrm\_00106*)

Note: Refer to Figure 7.6 for the layout of the tag.

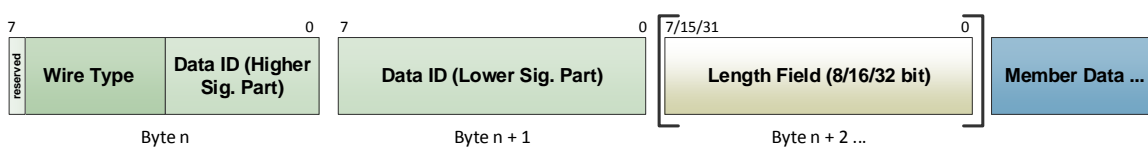

**Figure 7.6: SOME/IP Struct Tag Layout**

**[SWS\_SomeIpXf\_00269]** [The lower significant part of the Data ID of the member shall be encoded in bits 7-0 of the second byte of the tag. The higher significant part of the Data ID of the member shall be encoded in bits 3-0 of the first byte.] (*SRS\_Xfrm\_00106*)

Example: The Data ID of the member is 1266 (dec). Then bits 3-0 of the first byte are set to 0x4. The second byte is set to 0xF2.

**[SWS\_SomeIpXf\_00270]** [The wire type shall determine the type of the following data of the member. The value shall be assigned as shown in Table 7.9.] (*SRS\_Xfrm\_00106*)

Wire Type	Value
0	8 Bit Data Base data type
1	16 Bit Data Base data type
2	32 Bit Data Base data type
3	64 Bit Data Base data type
4	Complex Data Type: Array, Struct, String, Union with length field of static size (configured in data definition)
5	Complex Data Type: Array, Struct, String, Union with length field size 1 byte (ignore static definition)
6	Complex Data Type: Array, Struct, String, Union with length field size 2 byte (ignore static definition)
7	Complex Data Type: Array, Struct, String, Union with length field size 4 byte (ignore static definition)

**Table 7.9: Message Types**

Note: Wire type 4 ensures the compatibility with the current approach where the size of length fields is statically configured. This approach has the drawback that changing the size of the length field during evolution of interfaces is always incompatible. Thus, wire types 5, 6 and 7 allow to encode the size of the used length field in the transferred byte stream.

**[SWS\_SomelpXf\_00271]** [If `SOMEIPTransformationISignalProps.isDynamicLengthFieldSize` is set to false or is not defined, the transformer shall use wire type 4 for serializing complex types and shall use the fixed size length fields. The size of the length fields is defined in `SOMEIPTransformationISignalProps.sizeOfArrayLengthFields`, `sizeOfStructLengthFields` and `sizeOfUnionLengthFields`.] (*SRS\_Xfrm\_00106*)

**[SWS\_SomelpXf\_00272]** [`SOMEIPTransformationISignalProps.isDynamicLengthFieldSize` is set to true, the transformer shall use wire types 5,6,7 for serializing complex types and shall chose the size of the length field according to this wire type.] (*SRS\_Xfrm\_00106*)

**[SWS\_SomelpXf\_00273]** [A deserializer shall always be able to handle the wire types 4, 5, 6 and 7 independent of the setting of `SOMEIPTransformationISignalProps.isDynamicLengthFieldSize`] (*SRS\_Xfrm\_00106*)

**[SWS\_SomelpXf\_00274]** [If a Data ID is defined for an `ArgumentDataPrototype` or `ImplementationDataTypeElement` by means of `SOMEIPTransformationISignalProps.tlvDataId.id`, a tag shall be inserted in the serialized byte stream.] (*SRS\_Xfrm\_00106*)

Note: regarding existence of Data IDs, refer to [9].

**[SWS\_SomelpXf\_00275]** [If the datatype of the serialized member / argument is a basic datatype (wire types 0-3) and a Data ID is configured, the tag shall be inserted directly in front of the member/argument. No length field shall be inserted into the serialized stream.] (*SRS\_Xfrm\_00106*)

**[SWS\_SomelpXf\_00276]** [If the datatype of the serialized member/argument is not a basic datatype (wire type 4-7) and a Data ID is configured, the tag shall be inserted in front of the length field.] ([SRS\\_Xfrm\\_00106](#))

**[SWS\_SomelpXf\_00277]** [If the datatype of the serialized member/argument is not a basic datatype and a Data ID is configured, a length field shall always be inserted in front of the member/argument.] ([SRS\\_Xfrm\\_00106](#))

Rationale: The length field is required to skip unknown members/arguments during deserialization.

**[SWS\_SomelpXf\_00278]** [The length field shall always contain the length up to the next tag of the struct, but does not include the tag size and length field size itself.] ([SRS\\_Xfrm\\_00106](#))

**[SWS\_SomelpXf\_00279]** [If the member itself is of type struct, there shall be exactly one length field.] ([SRS\\_Xfrm\\_00106](#))

**[SWS\_SomelpXf\_00280]** [If the member itself is of type dynamic length string, there shall be exactly one length field.] ([SRS\\_Xfrm\\_00106](#))

**[SWS\_SomelpXf\_00281]** [If the member itself is of type fixed length string, there shall be exactly one length field corresponding to dynamic length strings.] ([SRS\\_Xfrm\\_00106](#))

Note: When serialized without tag, fixed length strings do not have a length field. For the serialization with tag, a length field is also required for fixed length strings in the same way as for dynamic length strings.

**[SWS\_SomelpXf\_00282]**{DRAFT} [If the member itself is of type dynamic length array, there shall be exactly one length field.] ([SRS\\_Xfrm\\_00106](#))

**[SWS\_SomelpXf\_00283]** [If the member itself is of type fixed length array, there shall be exactly one length field.] ([SRS\\_Xfrm\\_00106](#))

**[SWS\_SomelpXf\_00284]** [If the member itself is of type union, there shall be exactly one length field.] ([SRS\\_Xfrm\\_00106](#))

**[SWS\_SomelpXf\_00285]** [For the serialization of extensible structs and methods the length field shall cover the size of the type field, data and padding bytes if the member itself is of type union.] ([SRS\\_Xfrm\\_00106](#))

Note: For the serialization without tags, the length field of unions does not cover the type field (see [\[SWS\\_SomelpXf\\_00226\]](#)). For the serialization with tags, it is required that the complete content of the serialized union is covered by the length field.

**[SWS\_SomelpXf\_00286]** [A member of a non-extensible (standard) struct which is of type extensible struct, shall be serialized according to the requirements for extensible structs.] ([SRS\\_Xfrm\\_00106](#))

**[SWS\_SomelpXf\_00287]** [A member of an extensible struct which is of type non-extensible (standard) struct, shall be serialized according to the requirements for standard structs.](SRS\_Xfrm\_00106)

**[SWS\_SomelpXf\_00288]** [For the serialization of extensible structs and methods no alignment shall be applied.](SRS\_Xfrm\_00106)

Rationale: When alignment greater 8 bits is used, the serializer may add padding bytes after variable length data. The padding bytes are not covered by the length field. If the receiver does not know the Data ID of the member, it also does not know that it is variable length data and that there might be padding bytes.

**[SWS\_SomelpXf\_00289]** [If the attribute `isStructWithOptionalElement` of the `ImplementationDataType` representing the extensible struct is set to true, the transformer shall ignore the first `ImplementationDataTypeElement` and shall not serialize or deserialize it.](SRS\_Xfrm\_00106)

Rationale: the first `ImplementationDataTypeElement` represents the availability bitfield which is not transferred on the wire.

**[SWS\_SomelpXf\_00290]** [The transformer shall only serialize an optional member of a struct if the corresponding bit in the availability bitfield is set as follows:

```
(availabilityBitfield[(pos/8)] & (1<<(pos mod 8))) != 0
```

](SRS\_Xfrm\_00106)

**[SWS\_SomelpXf\_00291]** [If an optional member is available in the serialized byte stream, the transformer shall set the corresponding bit in the availability bitfield as follows:

```
availabilityBitfield[(pos/8)] = availabilityBitfield[(pos/8)] | (1<<(pos mod 8))
```

](SRS\_Xfrm\_00106)

**[SWS\_SomelpXf\_00292]** [If an optional member is not available in the serialized byte stream, the transformer shall clear the corresponding bit in the availability bitfield as follows:

```
availabilityBitfield[(pos/8)] = availabilityBitfield[(pos/8)] & ~(1<<(pos mod 8))
```

](SRS\_Xfrm\_00106)

In the requirements [SWS\_SomelpXf\_00288], [SWS\_SomelpXf\_00289] and [SWS\_SomelpXf\_00290] `pos` is the position of the optional `ImplementationDataTypeElement` among all optional `ImplementationDataTypeElements` within the `ImplementationDataType` starting with `pos = 0`.

Note: Non-optional `ImplementationDataTypeElements` do not count since they do not need a bit in the `availabilityBitfield`. So the bit position within the `availabilityBitfield` is determined by the order of the optional `ImplementationDataTypeElements`. Examples:

- 1st optional `ImplementationDataTypeElement` (`pos=0`):

(availabilityBitfield[0] & 0x01) != 0

- 8th optional ImplementationDataTypeElement (pos=7):

(availabilityBitfield[0] & 0x80) != 0

- 9th optional ImplementationDataTypeElement (pos=8):

(availabilityBitfield[1] & 0x01) != 0

**[SWS\_SomelpXf\_00295]** [If an optional member is not available in the received serialized byte stream, the transformer shall keep the memory section occupied by this optional element without modification.] ([SRS\\_Xfrm\\_00106](#))

**[SWS\_SomelpXf\_00293]** [If the transformer reads an unknown Data ID (i.e. not contained in its data definition), it shall skip the unknown member/argument by using the information of the wire type and length field.] ([SRS\\_Xfrm\\_00106](#))

**[SWS\_SomelpXf\_00294]** [If the transformer cannot find a required (i.e. non-optional) member defined in its data definition in the serialized byte stream, the deserialization shall be aborted with E\_SER\_MALFORMED\_MESSAGE. For examples, please refer to [10].] ([SRS\\_Xfrm\\_00106](#))

#### 7.2.4.4 Strings

**[SWS\_SomelpXf\_00053]** [Strings shall be encoded using Unicode and terminated with a

"\textbackslash0"-character

for both fixed-length and dynamic-length strings. Unused space shall be filled using "\0".] ([SRS\\_Xfrm\\_00101](#))

**[SWS\_SomelpXf\_00054]** [Different Unicode encoding shall be supported including UTF-8, UTF-16BE, and UTF-16LE. Since these encoding have a dynamic length of bytes per character, the maximum length in bytes is up to three times the length of characters in UTF-8 plus 1 Byte for the termination with a "\0" or two times the length of the characters in UTF-16 plus 2 Bytes for a "\0". UTF-8 character can be up to 6 bytes and an UTF-16 character can be up to 4 bytes.] ([SRS\\_Xfrm\\_00101](#))

**[SWS\_SomelpXf\_00055]** [UTF-16LE and UTF-16BE strings shall be zero terminated with a

"\textbackslash0"-character

. This means they shall end with (at least) two 0x00 Bytes.] ([SRS\\_Xfrm\\_00101](#))

**[SWS\_SomelpXf\_00056]** [UTF-16LE and UTF-16BE strings shall have an even length.] ([SRS\\_Xfrm\\_00101](#))

**[SWS\_SomelpXf\_00057]** [For UTF-16LE and UTF-16BE strings having an odd length the last byte shall be silently removed by the receiving SOME/IP transformer.] ([SRS\\_Xfrm\\_00101](#))

**[SWS\_SomelpXf\_00248]** [In case of UTF-16LE and UTF-16BE strings having an odd length, after removal of the last byte, the two bytes before shall be 0x00 bytes (termination) for a string to be valid.] ([SRS\\_Xfrm\\_00101](#))

**[SWS\_SomelpXf\_00058]** [All strings shall always start with a Byte Order Mark (BOM). The BOM shall be included in fixed-length-strings as well as dynamic-length strings.] ([SRS\\_Xfrm\\_00101](#))

For the specification of BOM, see [11] and [12]. Please note that the BOM is used in the serialized strings to achieve compatibility with Unicode.

**[SWS\_SomelpXf\_00239]** [The String specific serialization will only be triggered if an Unicode String is detected and `implementsLegacyStringSerialization` is `false`.] ([SRS\\_Xfrm\\_00101](#))

For the details of the recognition and serialization of fixed- and dynamic-length strings see chapter 7.2.4.4.1 and chapter 7.2.4.4.2.

**[SWS\_SomelpXf\_00059]** [The receiving SOME/IP transformer implementation shall check the BOM and handle a missing BOM or a malformed BOM as an error.] ([SRS\\_Xfrm\\_00101](#))

**[SWS\_SomelpXf\_00060]** [The BOM shall be added by the SOME/IP sending transformer implementation.] ([SRS\\_Xfrm\\_00101](#))

#### 7.2.4.4.1 Strings (fixed length)

The length of the string (this includes the "\0") in Bytes is specified in the data type definition.

**[SWS\_SomelpXf\_00240] Recognition of UTF-8 Fixed Length Strings** [An UTF-8 Fixed Length String shall be detected if an `ApplicationPrimitiveDataType` and an `ImplementationDataType` with the following pattern are used:

- `ApplicationPrimitiveDataType`
  - with `category` equal to `STRING`
  - `ApplicationPrimitiveDataType.swDataDefProps.swTextProps.baseType` refers to a `BaseType` with `baseTypeDefinition.baseType-Encoding` equal to `UTF-8`
- `ImplementationDataType`
  - with `category` `ARRAY`

- that contains exactly one `ImplementationDataTypeElement` that boils down to a uint8 `ImplementationDataType`:
  - \* `ImplementationDataTypeElement.arraySize` is set to a value
  - \* `ImplementationDataTypeElement.arraySizeSemantics` is set to `fixedSize`

](SRS\_Xfrm\_00101)

**[SWS\_SomelpXf\_00241] Recognition of UTF-16 Fixed Length Strings** [An UTF-16 Fixed Length String shall be detected if an `ApplicationPrimitiveDataType` and an `ImplementationDataType` with the following pattern are used:

- `ApplicationPrimitiveDataType`
  - with `category` equal to `STRING`
  - `ApplicationPrimitiveDataType.swDataDefProps.swTextProps.baseType` refers to a `BaseType` with `baseTypeDefinition.baseTypeEncoding` equal to `UTF-16`
- `ImplementationDataType`
  - with `category` `ARRAY`
  - that contains exactly one `ImplementationDataTypeElement` that boils down to a uint16 `ImplementationDataType`:
    - \* `ImplementationDataTypeElement.arraySize` is set to a value
    - \* `ImplementationDataTypeElement.arraySizeSemantics` is set to `fixedSize`

](SRS\_Xfrm\_00101)

**[SWS\_SomelpXf\_00244] Serialization of fixed length strings** [Serialization of fixed length strings shall consist of the following steps:

1. Check whether the string terminates with `0x00` (UTF-8) or `0x0000` (UTF-16). If not, a `E_SER_GENERIC_ERROR` error shall be issued.
2. Appending BOM at the beginning of the output buffer, if BOM is not already available in the first three (UTF-8) or two (UTF-16) bytes of the to be serialized array containing the string. If the BOM is already present, simply copy the BOM into the output buffer.
3. Copying the string data (the number of bytes according to the string's fixed length) from the array into the output buffer, optionally performing a conversion between UTF-16LE and UTF-16BE between ECU and network byte order if `BaseTypeDirectDefinition.byteOrder` and `SOMEIPTransformationDescription.byteOrder` have different values

](SRS\_Xfrm\_00101)



**[SWS\_SomelpXf\_00246] Deserialization of fixed length strings** [Deserialization of fixed length strings shall consist of the following steps:

1. Check whether the string starts with a BOM. If not, a `MALFORMED_MESSAGE` error shall be issued
2. Check whether BOM has the same value as `SOMEIPTransformationDescription.byteOrder`. If not, a `MALFORMED_MESSAGE` error shall be issued
3. Remove the BOM
4. Silently discard the last byte of the string in case of an UTF-16 string with odd length
5. Check whether the string terminates with `0x00` (UTF-8) or `0x0000` (UTF-16). If not, a `MALFORMED_MESSAGE` error shall be issued
6. Copy the string data (the number of bytes according to the string's fixed length) from the input buffer into the array, optionally performing a conversion between UTF-16LE and UTF-16BE between network and ECU byte order if `BaseTypeDirectDefinition.byteOrder` and `SOMEIPTransformationDescription.byteOrder` have different values.

]([SRS\\_Xfrm\\_00101](#))

#### 7.2.4.4.2 Strings (dynamic length)

Strings with dynamic length can be realized in an AUTOSAR system as an array with dynamic length that transports the single characters.

**[SWS\_SomelpXf\_00242] Recognition of UTF-8 Variable Length Strings** [An UTF-8 Fixed Length String shall be detected if an `ApplicationPrimitiveDataType` and an `ImplementationDataType` with the following pattern are used:

- `ApplicationPrimitiveDataType`
  - with `category` equal to `STRING`
  - `ApplicationPrimitiveDataType.swDataDefProps.swTextProps.baseType` refers to a `BaseType` with `baseTypeDefinition.baseTypeEncoding` equal to `UTF-8`
- `ImplementationDataType`

The `ImplementationDataType` shall be defined according to [TPS\_SWCT\_01650] as a `STRUCTURE` that contains exactly two `ImplementationDataTypeElements` and shall follow the rules defined by [constr\_1318]:

  - one `ImplementationDataTypeElement` represents the `Size Indicator` and has the `category` equal to `TYPE_REFERENCE` which points to a `uint8`, `uint16` or `uint32` `ImplementationDataType`

- one `ImplementationDataTypeElement` has the `category` equal to `ARRAY` and contains exactly one `ImplementationDataTypeElement` that boils down to a `uint8 ImplementationDataType`

](SRS\_Xfrm\_00101)

**[SWS\_SomelpXf\_00243] Recognition of UTF-16 Variable Length Strings** [An UTF-16 Fixed Length String shall be detected if an `ApplicationPrimitiveDataType` and an `ImplementationDataType` with the following pattern are used:

- `ApplicationPrimitiveDataType`
  - with `category` equal to `STRING`
  - `ApplicationPrimitiveDataType.swDataDefProps.swTextProps.baseType` refers to a `BaseType` with `baseTypeDefinition.baseTypeEncoding` equal to `UTF-16`
- `ImplementationDataType`

The `ImplementationDataType` shall be defined according to [TPS\_SWCT\_01650] as a `STRUCTURE` that contains exactly two `ImplementationDataTypeElements` and shall follow the rules defined by [constr\_1318]:

  - one `ImplementationDataTypeElement` represents the `Size Indicator` and has the `category` equal to `TYPE_REFERENCE` which points to a `uint8, uint16 or uint32 ImplementationDataType`
  - one `ImplementationDataTypeElement` has the `category` equal to `ARRAY` and contains exactly one `ImplementationDataTypeElement` that boils down to a `uint16 ImplementationDataType`

](SRS\_Xfrm\_00101)

**[SWS\_SomelpXf\_00245] Serialization of dynamic length strings** [Serialization of dynamic length strings shall consist of the following steps:

1. Check whether the string terminates with `0x00` (UTF-8) or `0x0000` (UTF-16). If not, a `E_SER_GENERIC_ERROR` error shall be issued.
2. Add the Length Field - The value of the length field shall be computed by multiplying the number of elements given by the size indicator with the size in bytes of each element (i.e., 1 for UTF-8 and 2 for UTF-16) increased by the size in bytes required by the BOM. The data type of the length field shall be determined from the `sizeofStringLengthFields`. If the attribute `sizeofStringLengthFields` is not configured then the default value of 32 bit shall be used as defined by [PRS\_SOMEIP\_00094]. The value of the length field shall comply with [SWS\_SomelpXf\_CONSTR\_0001].
3. Appending BOM at the beginning, if BOM is not already available in the first 3 (UTF-8) or 2 (UTF-16) bytes of the to be serialized array containing the string. If the BOM is already present, simply copy the BOM into the output buffer

4. Copying the string data (copy the the number of bytes according to the string's size indicator and the size of bytes of each element) from the array into the output buffer, optionally performing a conversion between UTF-16LE and UTF-16BE between ECU and network byte order `BaseTypeDirectDefinition.byteOrder` and `SOMEIPTransformationDescription.byteOrder` have different values

]([SRS\\_Xfrm\\_00101](#))

#### [SWS\_SomeIpXf\_00247] Deserialization of dynamic length strings

[Deserialization of dynamic length strings shall consist of the following steps:

1. Check whether the string starts with a BOM. If not, a `MALFORMED_MESSAGE` error shall be issued
2. Check whether BOM has the same value as `SOMEIPTransformationDescription.byteOrder`. If not, a `MALFORMED_MESSAGE` error shall be issued
3. Remove the BOM and reduce the value of the length field accordingly
4. Silently discard the last byte of the string in case of an UTF-16 string with odd length (according to the reduced value of the length field)
5. Check whether the string terminates with `0x00` (UTF-8) or `0x0000` (UTF-16). If not, a `MALFORMED_MESSAGE` error shall be issued
6. Check whether the length of the received dynamic length string is less or equal than the specified maximum length of the string (`ApplicationPrimitiveDataType.swTextProps.swMaxTextSize` or `arraySize` of `ImplementationDataTypeElement` of category `ARRAY`). If not, a `MALFORMED_MESSAGE` error shall be issued.
7. Copy the string data (copy the number of bytes according to the string's reduced value of the length field) from the input buffer into the array, optionally performing a conversion between (UTF-16LE) and (UTF-16BE) between ECU and bus if `BaseTypeDirectDefinition.byteOrder` and `SOMEIPTransformationDescription.byteOrder` have different values.

]([SRS\\_Xfrm\\_00101](#))

#### 7.2.4.5 Arrays (fixed length)

[SWS\_SomeIpXf\_00069] [The length of fixed length arrays is defined by the datatype definition.]([SRS\\_Xfrm\\_00101](#))

They can be seen as repeated elements. In chapter [7.2.4.7](#) dynamic length arrays are shown, which can be also used. Fixed length arrays are easier for use in very small devices. Dynamic length arrays might need more resources on the ECU using them.

SOME/IP allows to add a length field of 8, 16 or 32 bit in front of arrays. The length field of an array describes the number of bytes of the array. This allows extensible arrays which allow better migration of interfaces.

**[SWS\_SomeIpXf\_00220]** [If attribute `sizeofArrayLengthFields` of `SOMEIPTransformationISignalProps` is set to a value greater 0, a length field shall be inserted in front of every serialized array.]([SRS\\_Xfrm\\_00101](#))

Note:

[\[SWS\\_SomeIpXf\\_00220\]](#) also applies to nested arrays which means that additionally every nested fixed-size array has its own length field.

**[SWS\_SomeIpXf\_00256]** [If attribute `sizeofArrayLengthField` of `SOMEIPTransformationProps` is set to a value greater 0, a length field shall be inserted in front of the serialized array for which the `SOMEIPTransformationProps` is defined. (See [TPS\_SYST\_02121])]([SRS\\_Xfrm\\_00101](#))

Note:

[\[SWS\\_SomeIpXf\\_00256\]](#) applies if the length fields of the array and all nested arrays contained are configured to different values for the lengths of the length fields via `SOMEIPTransformationProps`

**[SWS\_SomeIpXf\_00257]** [If `SOMEIPTransformationProps.sizeOfArrayLengthField` is present for a static size array the data type for the length field of the array shall be determined by the value of `SOMEIPTransformationProps.sizeOfArrayLengthField`:

- `uint8` if `sizeofArrayLengthField` equals 1
- `uint16` if `sizeofArrayLengthField` equals 2
- `uint32` if `sizeofArrayLengthField` equals 4
- Otherwise [\[SWS\\_SomeIpXf\\_00221\]](#) applies.

]([SRS\\_Xfrm\\_00101](#))

**[SWS\_SomeIpXf\_00221]** [The data type of the length field for an array shall be determined by the value of `SOMEIPTransformationISignalProps.sizeOfArrayLengthFields` of the serialized `ISignal`:

- `uint8` if `sizeofArrayLengthFields` equals 1
- `uint16` if `sizeofArrayLengthFields` equals 2
- `uint32` if `sizeofArrayLengthFields` equals 4

]([SRS\\_Xfrm\\_00101](#))

**[SWS\_SomeIpXf\_00222]** [The serializing SOME/IP transformer shall write the size (in bytes) of the serialized array (without the size of the length field) into the length field of the array.]([SRS\\_Xfrm\\_00101](#))

**[SWS\_SomelPxf\_00223]** [If the length is greater than the expected length of an array (as specified in the data type definition) a deserializing SOME/IP transformer shall only interpret the expected data and skip the unexpected.]([SRS\\_Xfrm\\_00101](#))

To determine the start of the next expected data following the skipped unexpected part, the SOME/IP transformer can use the supplied length information.

**7.2.4.5.1 One-dimensional**

The one-dimensional arrays with fixed length  $n$  carry exactly  $n$  elements of the same type. The layout is shown in Figure 7.7.

**[SWS\_SomelPxf\_00070]** [A one-dimensional array with fixed length shall be serialized by concatenating the array elements in order.]([SRS\\_Xfrm\\_00101](#))

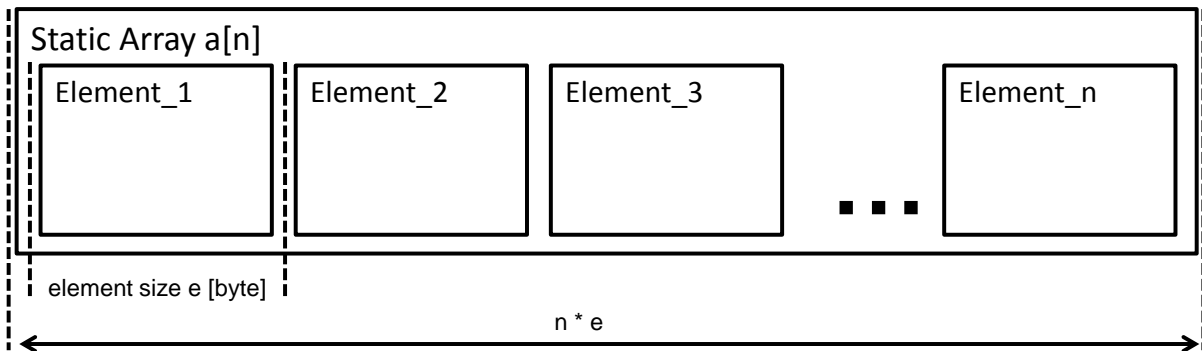

**Figure 7.7: One-dimensional array (fixed length)**

**7.2.4.5.2 Multidimensional**

**[SWS\_SomelPxf\_00072]** [The serialization of multidimensional arrays shall happen in row-major order (in-memory layout of multidimensional arrays in the C programming language)]([SRS\\_Xfrm\\_00101](#))

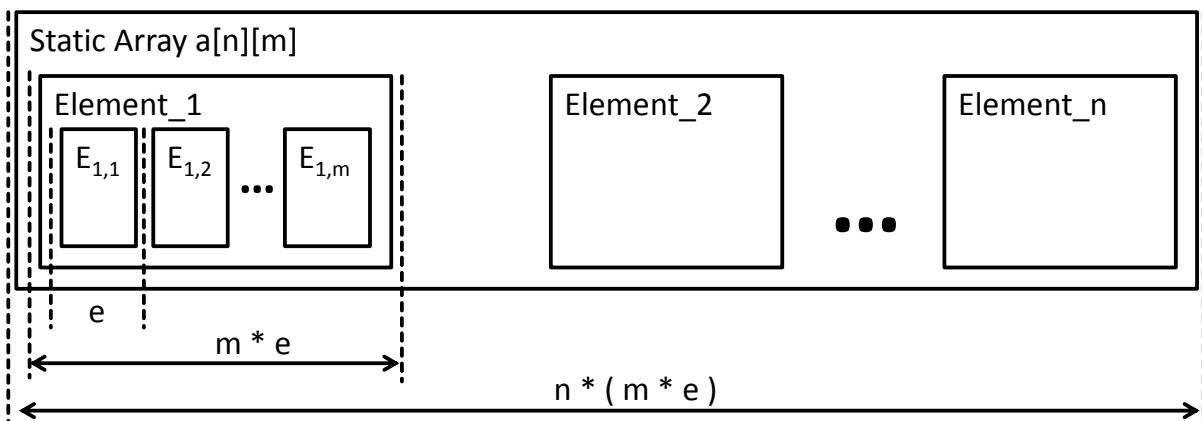

**Figure 7.8: Multidimensional array (fixed length)**

Consult AUTOSAR SWS RTE chapter 5.3.4.4 for Arrays.

#### 7.2.4.6 Optional Parameters / Optional Elements

Optional Elements can be encoded as array with 0 to 1 elements. For the serialization of arrays with dynamic length see Chapter [7.2.4.7](#).

#### 7.2.4.7 Dynamic Length Arrays / Variable Size Arrays

Variable size arrays are implemented in AUTOSAR as structs with two members

- a size indicator which is an integer and holds the number of valid elements in the array
- the array with variable size

In SOME/IP variable size arrays are implemented in a similar manner. Only the size indicator is replaced by a length indicator.

- a length indicator which is an integer and holds the length (in bytes) of the following variable size array
- the array which contains the valid elements of the variable size array

In AUTOSAR also so called "old-world" variable-size array data types exist which don't have a size indicator. These are not supported by data transformation in general and hence also not supported by the SOME/IP transformer. For details, refer to [constr\_1387] ([9, System Template]), [TPS\_SWCT\_01644], [TPS\_SWCT\_01645], [TPS\_SWCT\_01642] and [TPS\_SWCT\_01643].

**[SWS\_SomelpXf\_00076]** [A variable size array embedded in a structure which also contains a size indicator shall be serialized as the concatenation of the following elements:

- the length indicator which holds the length (in bytes) of the following variable size array
- the array which contains the valid elements of the variable size array

where

- the data type of the length field shall be determined as specified in [\[SWS\\_SomelpXf\\_00234\]](#)
- the array shall be serialized like a static size array but does only contain the valid elements. The number of elements to serialize shall be taken from the size indicator.

]([SRS\\_Xfrm\\_00101](#))

[SWS\_SomeIpXf\_00234] [A variable size array is represented in AUTOSAR by an `ImplementationDataType` with the category `STRUCTURE` and two sub-elements (namely *payload* and *size indicator*). The data type of the length fields for the SOME/IP message for a variable size array shall be determined from the `sizeOfArrayLengthFields`. If the attribute `sizeOfArrayLengthFields` is not configured then the default value of 32 bit shall be used as defined by [PRS\_SOMEIP\_00945].

In case of nested variable size arrays, AUTOSAR allows to use profiles to specify size indicators which apply to more than one variable size array nested within the same `ImplementationDataType`. Depending on the specific profile (`dynamicArraySizeProfile`), the data type of the length fields inside the SOME/IP message shall be determined differently:

- `VSA_LINEAR`  
The data type of the SOME/IP length field shall be determined from the single `sizeOfArrayLengthFields`. If the attribute `sizeOfArrayLengthFields` is not configured then the default value of 32 bit shall be used as defined by [PRS\_SOMEIP\_00945].
- `VSA_SQUARE`  
All data type of the SOME/IP length fields shall be determined from the single `sizeOfArrayLengthFields`. If the attribute `sizeOfArrayLengthFields` is not configured then the default value of 32 bit shall be used as defined by [PRS\_SOMEIP\_00945].
- `VSA_RECTANGULAR`  
The data type of all SOME/IP length fields for all dimensions (nesting level) shall be determined from the single `sizeOfArrayLengthFields`. If the attribute `sizeOfArrayLengthFields` is not configured then the default value of 32 bit shall be used as defined by [PRS\_SOMEIP\_00945].
- `VSA_FULLY_FLEXIBLE`  
The data type of all SOME/IP length fields for all variable size arrays shall be determined from the single `sizeOfArrayLengthFields`. If the attribute `sizeOfArrayLengthFields` is not configured then the default value of 32 bit shall be used as defined by [PRS\_SOMEIP\_00945].

]([SRS\\_Xfrm\\_00101](#), [SRS\\_Xfrm\\_00008](#))

This means only the first  $m$  elements of the variable size array are serialized where  $m$  is the value of the size indicator.

The layout of dynamic arrays is shown in 7.9 and Figure 7.10 where  $L_1$  and  $L_2$  denote the length in bytes.

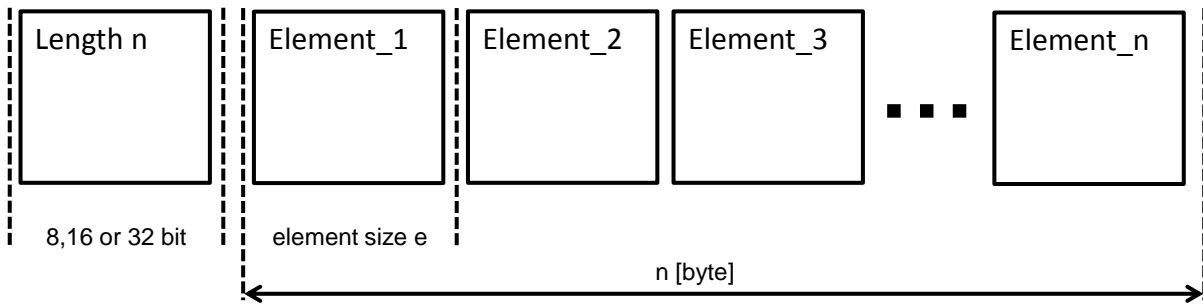

**Figure 7.9: One-dimensional array (dynamic length) (Example)**

In the one-dimensional array one length field is used, which carries the size in bytes of the valid elements in the array.

**[SWS\_SomeIpXf\_00235]** [If the value of `dynamicArraySizeProfile` equals `VSA_LINEAR`, the value of the length field of the serialized variable size array shall be calculated based on the value of the size indicator of the AUTOSAR data type.] (*SRS\_Xfrm\_00101, SRS\_Xfrm\_00008*)

The number of static length elements can be easily calculated by dividing the array length  $n$  by the Byte size of an element.

In the case of dynamical length elements the number of elements cannot be calculated but the elements must be parsed sequentially.

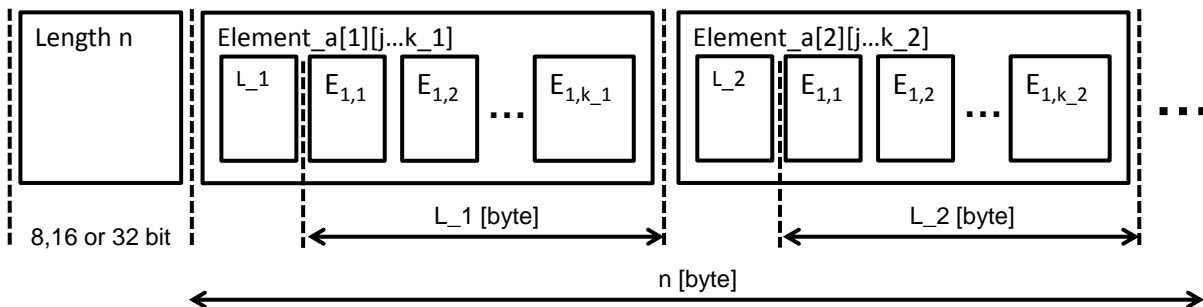

**Figure 7.10: Multidimensional array (dynamic length) (Example)**

In case of multidimensional variable size arrays, each variable size array needs to have its own length field, independent of the way how the variable size array is designed in the AUTOSAR data type (i.e. independent from the value of `dynamicArraySizeProfile`) as specified in [SWS\_SomeIpXf\_00234]. Hence it is supported to have different length columns and different length rows in the same dimension. See  $k_1$  and  $k_2$  in Figure 7.10.

**[SWS\_SomeIpXf\_00236]** [If the value of `dynamicArraySizeProfile` of a multidimensional variable size array equals `VSA_SQUARE`, the value of all length fields of the nested serialized variable size arrays that belong to this multi-dimensional variable size arrays shall be calculated based on the value of the single size indicator of the AUTOSAR data type.] (*SRS\_Xfrm\_00101, SRS\_Xfrm\_00008*)



In case of `VSA_SQUARE`, the AUTOSAR data type only has one size indicator. The value of this size indicator will be used as base for the calculation for the value of all length fields of such a multi-dimensional variable size array.

**[SWS\_SomelpXf\_00237]** [If the value of `dynamicArraySizeProfile` of a multi-dimensional variable size array equals `VSA_RECTANGULAR`, the values of all length fields of the nested serialized variable size arrays of the same nesting level (i.e. the same dimension) that belong to this multi-dimensional variable size array shall be calculated based on the values of the size indicators of the AUTOSAR data type for this respective nesting level.] (*SRS\_Xfrm\_00101, SRS\_Xfrm\_00008*)

In case of `VSA_RECTANGULAR`, the AUTOSAR data type has exactly one size indicator for each dimension of the the multi-dimensional variable size array. For all variable size arrays in one dimension, the value of the according size indicator of this dimension will be used as base for the calculation of the values of all length fields of this dimension.

**[SWS\_SomelpXf\_00238]** [If the value of `dynamicArraySizeProfile` of a multi-dimensional variable size array equals `VSA_FULLY_FLEXIBLE`, the values of all length fields of the nested serialized variable size arrays that belong to this multi-dimensional variable size arrays shall be calculated based on the value of the size indicator of the corresponding variable size array that is contained in the AUTOSAR data type.] (*SRS\_Xfrm\_00101, SRS\_Xfrm\_00008*)

In case of `VSA_FULLY_FLEXIBLE`, in the AUTOSAR data type the outer variable size array and each nested variable size arrays has its own size indicator. For the calculation of the values of the length fields both of the outer and all nested variable size arrays the according values of the size indicators of the AUTOSAR data type will be used as base.

The RTE provides a buffer where serialization result will be written into by the SOME/IP transformer which is large enough to keep the length field and a fully filled dynamic array.

#### 7.2.4.8 Bitfield

**[SWS\_SomelpXf\_00300]** [Bitfields shall be transported as basic datatypes `uint8/uint16/uint32`.] (*()*)

#### 7.2.4.9 Union / Variant

A union (also called variant) is a parameter that can contain different types of elements. For example, if one defines a union of type `uint8` and type `uint16`, the union shall carry an element of `uint8` or `uint16`.

The union serialization will only be triggered if the pattern defined in **[SWS\_SomelpXf\_00249]** applies.

**[SWS\_SomelpXf\_00249]** [A union shall be detected if an `ImplementationDataType` with the following pattern (named wrapped union data type) is used: `ImplementationDataType` with category `STRUCTURE` that contains exactly two `ImplementationDataTypeElements`:

- memberSelector: `ImplementationDataTypeElement` which represents the type field that boils down to a `uint8`, `uint16` or `uint32` `ImplementationDataType`
- payload: `ImplementationDataTypeElement` of category `UNION` which represents the actual union

]([SRS\\_Xfrm\\_00101](#))

When using different types of elements the alignment of subsequent parameters may be distorted. To resolve this, padding might be needed.

**[SWS\_SomelpXf\_00088]** [The default serialization layout of unions in SOME/IP is shown in Table 7.10.]([SRS\\_Xfrm\\_00101](#))

Length field (optional)
Type field
Element including padding [sizeof(padding) = length - sizeof(element)]

**Table 7.10: Default serialization layout of unions**

SOME/IP allows to add a length field of 8, 16 or 32 bit in front of unions. The length field of a union describes the number of bytes in the union.

This allows the deserializer to quickly calculate the position where the data after the union begin in the serialized data stream. This gets necessary if the union contains data which are larger than expected, for example if a struct was extended with appended new members and only the first "old" members are deserialized by the SOME/IP transformer.

**[SWS\_SomelpXf\_00224]** [If attribute `sizeofUnionLengthFields` of `SOMEIPTransformationISignalProps` is set to a value greater 0, a length field shall be inserted in front of every serialized union.]([SRS\\_Xfrm\\_00101](#))

Note:

[\[SWS\\_SomelpXf\\_00224\]](#) also applies to nested unions which means that additionally every nested union has its own length field.

**[SWS\_SomelpXf\_00254]** [If attribute `sizeofUnionLengthField` of `SOMEIPTransformationProps` is set to a value greater 0, a length field shall be inserted in front of the serialized union for which the `SOMEIPTransformationProps` is defined. (See [TPS\_SYST\_02121]).]([SRS\\_Xfrm\\_00101](#))

Note:

[\[SWS\\_SomelpXf\\_00254\]](#) applies if the length fields of the union and all nested unions

contained within the root union are configured to different values for the lengths of the length fields via [SOMEIPTransformationProps](#).

**[SWS\_SomelpXf\_00225]** [The data type of the length field of the union and all nested unions within the union shall be determined by the value of [SOMEIPTransformationISignalProps.sizeOfUnionLengthFields](#) of the serialized [ISignal](#):

- *uint8* if [sizeOfUnionLengthFields](#) equals 1
- *uint16* if [sizeOfUnionLengthFields](#) equals 2
- *uint32* if [sizeOfUnionLengthFields](#) equals 4

]([SRS\\_Xfrm\\_00101](#))

**[SWS\_SomelpXf\_00258]** [If [SOMEIPTransformationProps.sizeOfUnionLengthField](#) is present for a union the data type of the length field for the union shall be determined by the value of [SOMEIPTransformationProps.sizeOfUnionLengthField](#):

- *uint8* if [sizeOfUnionLengthFields](#) equals 1
- *uint16* if [sizeOfUnionLengthFields](#) equals 2
- *uint32* if [sizeOfUnionLengthFields](#) equals 4
- Otherwise **[SWS\_SomelpXf\_00225]** applies.

]([SRS\\_Xfrm\\_00101](#))

**[SWS\_SomelpXf\_00226]** [The serializing SOME/IP transformer shall write the size (in bytes) of the serialized union (including padding bytes but without the size of the length field and type field) into the length field of the union. This requirement does not apply for the serialization of extensible structs and methods.]([SRS\\_Xfrm\\_00101](#))

Note: See also chapter [7.2.4.3](#).

**[SWS\_SomelpXf\_00227]** [If the length is greater than the expected length of a union (as specified in the data type definition) a deserializing SOME/IP transformer shall only interpret the expected data and skip the unexpected.]([SRS\\_Xfrm\\_00101](#))

To determine the start of the next expected data following the skipped unexpected part, the SOME/IP transformer can use the supplied length information.

The length of the type field shall be 32, 16, 8 or 0 bits.

The type field describes the type of the element.

**[SWS\_SomelpXf\_00250]** [The data type of the type field of the union shall be determined from the [ImplementationDataType](#) of the first [ImplementationDataTypeElement](#) (memberSelector) in the wrapped union data type defined in **[SWS\_SomelpXf\_00249]**.]([SRS\\_Xfrm\\_00101](#))

**[SWS\_SomelpXf\_00098]** [Possible values of the type field are defined by the data type specification of the union. The types are encoded as in the data type in ascending

order starting with 1. The 0 is reserved for the NULL type - i.e. an empty union.]  
([SRS\\_Xfrm\\_00101](#))

**[SWS\_SomelpXf\_00251]** [The value of the type field shall be set to the value defined by the first [ImplementationDataTypeElement](#) (memberSelector) in the wrapped union data type defined in [[SWS\\_SomelpXf\\_00249](#)].] ([SRS\\_Xfrm\\_00101](#))

**[SWS\_SomelpXf\_00099]** [The element is serialized depending on the type in the type field. This also defines the length of the data. All bytes behind the data that are covered by the length, are padding. The deserializer shall skip the padding bytes by calculating the required number according to the formula given in [[SWS\\_SomelpXf\\_00088](#)].] ([SRS\\_Xfrm\\_00101](#))

By using a struct in the data type definition, different padding layouts can be achieved.

#### 7.2.4.9.1 Example: Union of uint8/uint16 both padded to 32 bit

In this example a length of the length field is specified as 32 bits. The union shall support a uint8 and a uint16 as elements. Both are padded to the 32 bit boundary (length=4 Bytes).

A uint8 will be serialized like this:

Length = 4 Bytes			
Type = 1			
uint8	Padding 0x00	Padding 0x00	Padding 0x00

A uint16 will be serialized like this:

Length = 4 Bytes		
Type = 2		
uint16	Padding 0x00	Padding 0x00

### 7.3 Protocol specification

This chapter describes the protocol of SOME/IP for Client/Server and Sender/Receiver communication.

#### 7.3.1 Client/Server Communication

**[SWS\_SomelpXf\_00106]** [For the SOME/IP request message, the SOME/IP transformer on the client-ECU has to do the following for payload and header:

- Construct the payload

- Optionally set the Request ID to a unique number (shall be unique for client only)
- Set the Protocol Version according [SWS\_SomeIpXf\_00029]
- Set the Interface Version. If `interfaceVersion` of `SOMEIPTransformationISignalProps` is set, this shall be used. Otherwise `interfaceVersion` of `SOMEIPTransformationDescription` shall be used.
- Set the Message Type to Request (i.e. 0x00)
- Set the Return Code to 0x00

](SRS\_Xfrm\_00102)

**[SWS\_SomeIpXf\_00120]** [To construct the payload of a request message all `arguments` of the `ClientServerOperation` which have `direction` IN or INOUT shall be serialized according to the order of the `ArgumentDataPrototypes` within the `ClientServerOperation`.](SRS\_Xfrm\_00102)

This can be seen graphically in Figure 7.11.

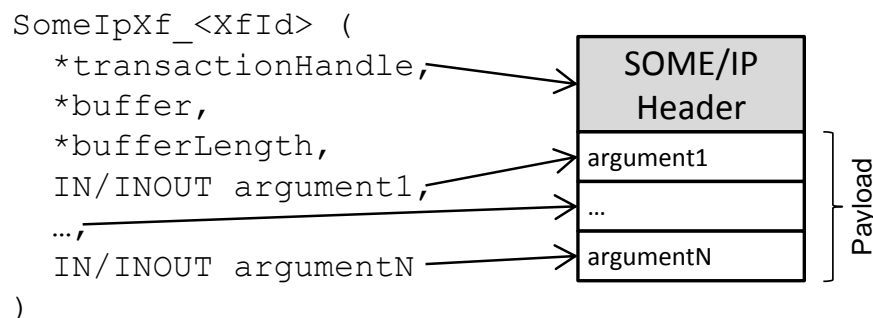

**Figure 7.11: Example for serialization of a Client/Server Request**

**[SWS\_SomeIpXf\_00200]** [If `csErrorReaction` of `TransformationISignalProps` is set to `autonomous` and the `returnValue` parameter handed over from RTE is greater or equal to 0x80, the SOME/IP transformer for a response of a client/server communication shall generate an error message according to [SWS\_SomeIpXf\_00201], else it shall generate a normal response according to [SWS\_SomeIpXf\_00107].](SRS\_Xfrm\_00102)

**[SWS\_SomeIpXf\_00107]** [The SOME/IP transformer on the server-ECU builds its header for the server response based on the header of the client's request and does in addition:

- Construct the payload
- Set the Message Type to RESPONSE (i.e. 0x80)
- If the `ClientServerOperation` has at least one `possibleError` defined, place the return value of the executed `ClientServerOperation` into the Return Code field and add 0x1F to adapt the number ranges in case the original return value was different from 0x00.

](SRS\_Xfrm\_00102)

Note: See also chapter 7.2.3.7.

**[SWS\_SomeIpXf\_00121]** [To construct the payload of a response message all arguments of the ClientServerOperation which have direction INOUT or OUT shall be serialized in the following order:

The ArgumentDataPrototypes with a direction of INOUT or OUT shall be serialized according to the order of the ArgumentDataPrototypes within the ClientServerOperation.](SRS\_Xfrm\_00102)

This can be seen graphically in Figure 7.12.

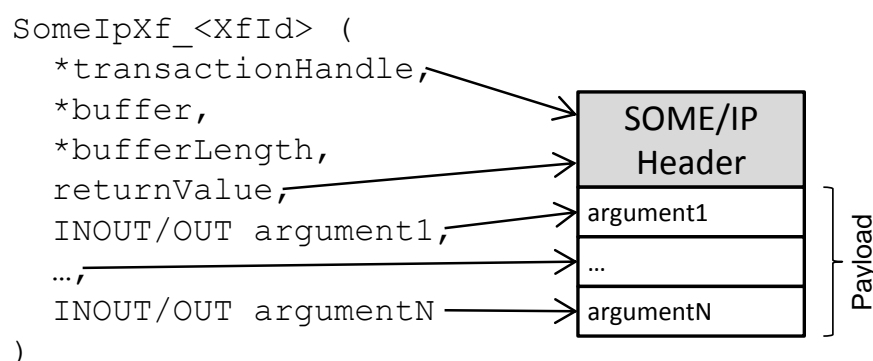

**Figure 7.12: Example for serialization of a Client/Server Response**

**[SWS\_SomeIpXf\_00201]** [The SOME/IP transformer on the server-ECU builds its header for an autonomous error response based on the header of the client’s request and does in addition:

- Construct no payload (the payload shall be empty)
- Set the Message Type to RESPONSE (i.e. 0x80)
- Adapt the return value by subtracting 0x80 from the parameter returnValue (calculation:  $adaptedReturnValue = returnValue - 0x80$ )
- Place the adaptedReturnValue into the Return Code field.

](SRS\_Xfrm\_00102)

Note: See also chapter 7.2.3.7.

This leads to an output of the SOME/IP transformer which is exactly as long as the SOME/IP header.

Note:

Error messages can only be sent as a response for client/server requests, not for Sender/Receiver communication or error messages.

**[SWS\_SomelpXf\_00202]** [A SOME/IP transformer on the server-ECU that builds an autonomous error response shall return with a return value equal to `E_OK` (See [\[SWS\\_SomelpXf\\_00141\]](#)).] ([SRS\\_Xfrm\\_00102](#))

If the SOME/IP transformer would return with a return code different from `E_OK` this would issue a hard error that prevents the RTE from sending the autonomous error response.

### 7.3.2 Sender/Receiver Communication

Session Handling ID counter is used to set the correct Request ID in the SOME/IP header in case of Sender/Receiver communication where session handling is activated.

**[SWS\_SomelpXf\_00212]** [One Session Handling ID counter (16 Bit) has to be maintained per transformer function for Sender/Receiver communication (see [\[SWS\\_SomelpXf\\_00138\]](#)) if `sessionHandlingSR` is set to `sessionHandlingActive`.] ([SRS\\_Xfrm\\_00008](#))

**[SWS\_SomelpXf\_00213]** [All Session Handling ID counters shall be initialized with `0x0001`.] ([SRS\\_Xfrm\\_00008](#))

**[SWS\_SomelpXf\_00108]** [The SOME/IP transformer on the sender side of transformed Sender/Receiver communication shall construct header and payload in the following way:

- Construct the payload
- Set the Request ID
  - to `0x00` if `sessionHandlingSR` of `SOMEIPTransformationISignalProps` is not set to `sessionHandlingActive`
  - the current value of the Session Handling ID counter otherwise
- Set the Protocol Version according [\[SWS\\_SomelpXf\\_00029\]](#)
- Set the Interface Version. If `interfaceVersion` of `SOMEIPTransformationISignalProps` is set, this shall be used. Otherwise `interfaceVersion` of `SOMEIPTransformationDescription` shall be used.
- Set the Message Type according to `messageType` of `SOMEIPTransformationISignalProps`:
  - NOTIFICATION (`0x02`) shall be used in the header if attribute `messageType` is set to `notification`
  - REQUEST\_NO\_RETURN (`0x01`) shall be used in the header if attribute `messageType` is set to `requestNoReturn`
- Set the Return Code to `0x00`

](SRS\_Xfrm\_00102)

In [SWS\_SomelpXf\_00108] it is specified when session handling is considered for messages which are sent. The SOME/IP transformer never checks the session ID on receiver side because the default behaviour of SOME/IP is for sender/receiver communication to ignore session IDs on receiver side.

**[SWS\_SomelpXf\_00176]** [The payload of a message for Sender/Receiver communication shall consists of the serialized data element that is transported.](SRS\_Xfrm\_00102)

Error handling and return codes have to be implemented by the application when needed.

### 7.3.3 Unqueued External Trigger Events

Unqueued external trigger events are used to trigger RPCs without any IN, INOUT or OUT arguments. They are realized by SOME/IP as fire-and-forget methods without arguments.

**[SWS\_SomelpXf\_00204]** [The SOME/IP transformer on the trigger source side of transformed external trigger events shall construct header in the following way:

- Set the Request ID
  - to 0x00 if `sessionHandlingSR` of `SOMEIPTransformationISignalProps` is not set to `sessionHandlingActive`
  - the current value of the Session Handling ID counter otherwise
- Set the Protocol Version according [SWS\_SomelpXf\_00029]
- Set the Interface Version. If `interfaceVersion` of `SOMEIPTransformationISignalProps` is set, this shall be used. Otherwise `interfaceVersion` of `SOMEIPTransformationDescription` shall be used.
- Set the Message Type to `REQUEST_NO_RETURN` (i.e. 0x01)
- Set the Return Code to 0x00

](SRS\_Xfrm\_00102)

**[SWS\_SomelpXf\_00205]** [The payload of a message for unqueued external trigger event communication shall be empty.](SRS\_Xfrm\_00102)

Error handling and return codes have to be implemented by the application when needed.



### 7.3.4 Error Handling

The error handling will be done solely in the application. SOME/IP only transports the errors.

Two different mechanisms for error transportation are supported: Return Code and Error Message

**[SWS\_SomelpXf\_00111]** [The SOME/IP transformer shall use the Return Code error handling.] ([SRS\\_Xfrm\\_00102](#), [SRS\\_Xfrm\\_00103](#))

Exceptions are specified in SOME/IP but not yet supported by this version of the SOME/IP transformer.

This can be used to handle all different application errors that might occur in the server. In addition, problems with the communication medium or intermediate components (e.g. switches) may occur, which have to be handled e.g. by means of reliable transport.

All messages have a return code field to carry the return code. However, only responses (Message Types 0x80 and 0x81) use this field to carry a return code to the request (Message Type 0x00) they answer. All other messages set this field to 0x00 (see Chapter 7.2.3.6). For more detailed errors the layout of the Error Message (Message Type 0x81) can carry specific fields for error handling, e.g. an Exception String. Error Messages are sent instead of Response Messages.

#### 7.3.4.1 Return Code

**[SWS\_SomelpXf\_00112]** [The Error Handling via Return Code shall be based on the Std\_ReturnType.] ([SRS\\_Xfrm\\_00102](#))

**[SWS\_SomelpXf\_00113]** [The Return Codes shall only be used for Client/Server communication.] ([SRS\\_Xfrm\\_00102](#))

**[SWS\_SomelpXf\_00170]** [In case of Client/Server communication the Return Code shall transport the `ApplicationErrors` of the executed `ClientServerOperation` if no SOME/IP error occurred.] ([SRS\\_Xfrm\\_00102](#))

This means: If a SOME/IP error occurred, this error is contained in the Return Code. If no SOME/IP error occurred, the Return Code contains the error (or success) code of the executed server runnable.

If an error occurs in case of client/server communication the server can be configured to create an autonomous error reaction which will be sent back to the client. In that response, the SOME/IP header fields `RequestId` and `InterfaceVersion` shall be equal to the values in the header of the request message.

This is realized by [\[SWS\\_SomelpXf\\_00201\]](#) which fills the header fields accordingly: `RequestId` is handed over from RTE and `InterfaceVersion` is consistent to the

request as the configuration of the SOME/IP transformer only allows the same `interfaceVersion` for request and response.

[SWS\_SomeIpXf\_00115] [The Return Codes of Table 7.11 are currently defined and shall be implemented as described:] ([SRS\\_Xfrm\\_00102](#))

ID	Name	Description
0x00	E_OK	No error occurred
0x01	E_NOT_OK	An unspecified error occurred
0x02	SOMEIPXF_E_UNKNOWN_SERVICE	The requested Service ID is unknown.
0x03	SOMEIPXF_E_UNKNOWN_METHOD	The requested Method ID is unknown. Service ID is known.
0x04	SOMEIPXF_E_NOT_READY	Service ID and Method ID are known. Application not running.
0x05	SOMEIPXF_E_NOT_REACHABLE	System running the service is not reachable (internal error code only).
0x06	SOMEIPXF_E_TIMEOUT	A timeout occurred (internal error code only).
0x07	SOMEIPXF_E_WRONG_PROTOCOL_VERSION	Version of SOME/IP protocol not supported
0x08	SOMEIPXF_E_WRONG_INTERFACE_VERSION	Interface version mismatch
0x09	SOMEIPXF_E_MALFORMED_MESSAGE	Deserialization error, so that payload cannot be deserialized.
0x0a	SOMEIPXF_E_WRONG_MESSAGE_TYPE	An unexpected message type was received (e.g. REQUEST_NO_RETURN for a method defined as REQUEST.)
0x0b	E_E2E	Not further specified E2E error
0x0c - 0x1f	RESERVED	Reserved for generic SOME/IP errors. These errors will be specified in future versions of this document.
0x20 - 0x5e	-	Specific <a href="#">ApplicationErrors</a> of <a href="#">ClientServerOperations</a> . These errors are the application errors specified by the <a href="#">ClientServerInterface</a> . As the range of <a href="#">ApplicationErrors</a> of the <a href="#">ClientServerInterface</a> is 0x01-0x3F, the value of an <a href="#">ApplicationError</a> has to be adapted for transport over SOME/IP by adding 0x1F.

**Table 7.11: Return Codes**

### 7.3.4.2 Communication Errors and Handling of Communication Errors

When considering the transport of Client/Server messages different reliability semantics exist:

- Maybe — the message might reach the communication partner
- At least once — the message reaches the communication partner at least once

- Exactly once — the message reaches the communication partner exactly once

When using these terms in regard to client/server communication the term applies to both messages (i.e. call and response or error).

While different implementations may implement different approaches, SOME/IP transformer currently achieves "maybe" reliability when using the UDP binding and "exactly once" reliability when using the TCP binding by a suitable configuration of the Ethernet modules. Further error handling is left to the application.

For "maybe" reliability, only a single timeout is needed, when using client/server communication in combination with UDP as transport protocol. Figure 7.13 shows the state machines for "maybe" reliability. The client's SOME/IP implementation has to wait for the response for a specified timeout. If the timeout occurs SOME/IP shall signal SOMEIPXF\_E\_TIMEOUT to the client application.

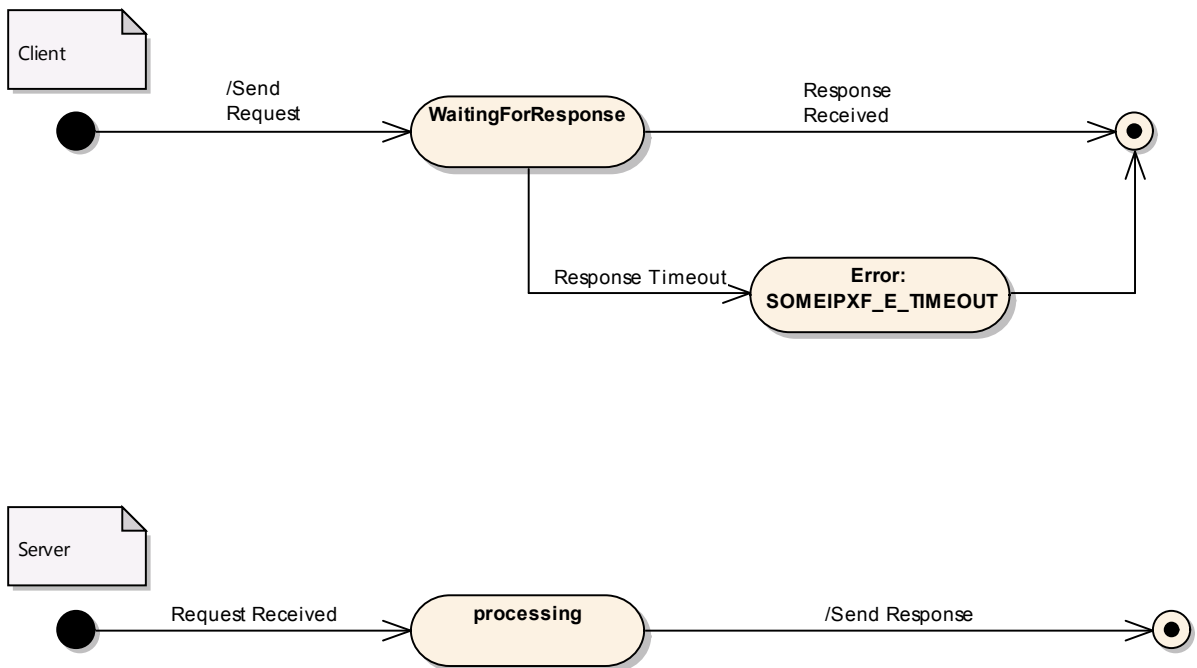

**Figure 7.13: State Machines for Reliability "Maybe"**

For "exactly once" reliability the TCP binding may be used, since TCP was defined to allow for reliable communication.

Additional mechanisms to reach higher reliability may be implemented in the application or in a SOME/IP implementation. Keep in mind that the communication does not have to implement these features. Chapter 7.3.4.2.1 describes such optional reliability mechanisms.

### 7.3.4.2.1 Application based Error Handling

The application can easily implement "at least once" reliability by using idempotent operations (i.e. operation that can be executed multiple times without side effects) and using a simple timeout mechanism. Figure 7.14 shows the state machines for "at least once" reliability using implicit acknowledgements. When the client sends out the request it starts a timer with the timeout specified for the specific method. If no response is received before the timer expires (round transition at the top), the client will retry the operation. A Typical number of retries would be 2, so that 3 requests are sent.

The number of retries, the timeout values, and the timeout behavior (constant or exponential back off) are outside of the SOME/IP specification.

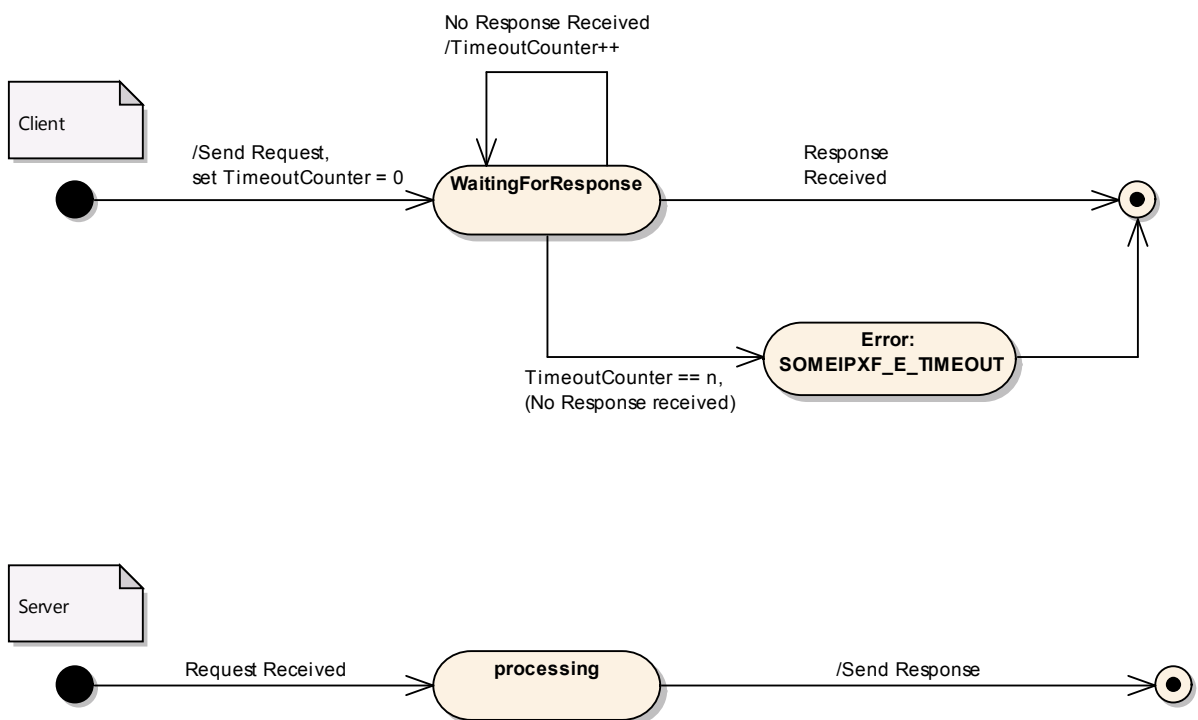

**Figure 7.14: State Machines for Reliability "At least once" (idempotent operations)**

## 7.4 Reserved and special identifiers for SOME/IP and SOME/IP-SD.

In this chapter an overview of reserved and special identifiers are shown.

[SWS\_SomIpXf\_00130] [Reserved and special Service-IDs are defined in Table 7.12.] (SRS\_Xfrm\_00008)

Service-ID	Description
0x0000	Reserved

0xFF00 - 0xFF1F	Reserved for Testing at OEM
0xFF20 - 0xFF3F	Reserved for Testing at Tier-1
0xFF40 - 0xFF5F	0xFF5F Reserved for ECU Internal Communication (Tier-1 proprietary)
0xFFFFE	Reserved for announcing non-SOME/IP service instances.
0xFFFF	SOME/IP and SOME/IP-SD special service.

**Table 7.12: Reserved and special Service-IDs**

**[SWS\_SomelpXf\_00131]** [Reserved and special Instance-IDs are defined in Table 7.13.] ([SRS\\_Xfrm\\_00008](#))

Instance-ID	Description
0x0000	Reserved
0xFFFF	All Instances

**Table 7.13: Reserved and special Instance-IDs**

**[SWS\_SomelpXf\_00132]** [Reserved and special Method-IDs/Event-IDs are defined in Table 7.14.] ([SRS\\_Xfrm\\_00008](#))

Method-ID	Description
0x0000	Reserved
0x7FFF	Reserved
0x8000	Reserved
0xFFFF	Reserved

**Table 7.14: Reserved and special Method-IDs/Event-IDs**

**[SWS\_SomelpXf\_00133]** [Method-IDs and Event-IDs of Service 0xFFFF are defined in Table 7.15.] ([SRS\\_Xfrm\\_00008](#))

Method-ID/Event-ID	Description
0x0000	SOME/IP Magic Cookie Messages
0x8000	SOME/IP Magic Cookie Messages
0x8100	SOME/IP-SD messages (events)

**Table 7.15: Method-IDs and Event-IDs of Service 0xFFFF**

**[SWS\_SomelpXf\_00134]** [Besides "otherserv" other names are supported by the configuration option. Table 7.16 gives an overview of the reserved names] ([SRS\\_Xfrm\\_00008](#))

Name	Description
hostname	Used to name a host or ECU.
instancename	Used to name an instance of a service.
servicename	Used to name a service.

otherserv	Used for non-SOME/IP Services.
-----------	--------------------------------

**Table 7.16: Reserved names of configuration options**

## 7.5 Error Classification

Section 7.5 "Error Handling" of the document "General Specification of Basic Software Modules" describes the error handling of the Basic Software in detail. Above all, it constitutes a classification scheme consisting of five error types which may occur in [13, SWS BSW General] modules.

Based on this foundation, the following section specifies particular errors arranged in the respective subsections below.

### 7.5.1 Development Errors

[SWS\_SomeIPxf\_00184] [

Type of error	Related error code	Error value
Error code if any other API service, except Get VersionInfo is called before the transformer module was initialized with Init or after a call to De Init	SOMEIPXF_E_UNINIT	0x01
Error code if an invalid configuration set was selected	SOMEIPXF_E_INIT_FAILED	0x02
API service called with wrong parameter	SOMEIPXF_E_PARAM	0x03
API service called with invalid pointer	SOMEIPXF_E_PARAM_POINTER	0x04

](SRS\_BSW\_00337)

### 7.5.2 Runtime Errors

There are no runtime errors

### 7.5.3 Transient Faults

There are no transient faults.

### 7.5.4 Production Errors

There are no production errors.

### 7.5.5 Extended Production Errors

All Extended Production Errors valid for SOME/IP Transformer are specified in [3, ASWS Transformer General].

## 8 API specification

### 8.1 Imported types

There are no imported types from other modules beyond those specified in [3, ASWS Transformer General].

In the Module Interlink Headers file which is imported by the SOME/IP Transformer, all [ImplementationDataTypes](#) known to the RTE are included. Using this mechanism, the SOME/IP Transformer knows all data types of data which shall be transformed.

### 8.2 Type definitions

[SWS\_SomelpXf\_00183] [

<b>Name</b>	SomelpXf_ConfigType	
<b>Kind</b>	Structure	
<b>Elements</b>	implementation specific	
	<b>Type</b>	–
	<b>Comment</b>	–
<b>Description</b>	This is the type of the data structure containing the initialization data for the transformer.	
<b>Available via</b>	SomelpXf.h	

]([SRS\\_BSW\\_00404](#), [SRS\\_BSW\\_00441](#))

### 8.3 Function definitions

The SOME/IP transformer provides the specific interfaces generally required by [3, ASWS Transformer General].

[SWS\_SomelpXf\_00150] [The SOME/IP Transformer shall only provide functions for transformers where the [TransformationTechnology](#) is referenced as the first reference in the list of ordered references `transformer` from a [DataTransformation](#) to a [TransformationTechnology](#).]()

That means, only the first transformer in a transformer chain can be a SOME/IP Transformer because serializer transformer are in general only allowed to be the first transformer in a chain.

#### 8.3.1 SomelpXf\_ExtractProtocolHeaderFields

[SWS\_SomelpXf\_91001] [



<b>Service Name</b>	SomeIpXf_ExtractProtocolHeaderFields	
<b>Syntax</b>	<pre>Std_ReturnType SomeIpXf_ExtractProtocolHeaderFields (     const uint8* buffer,     uint32 bufferLength,     Std_MessageType* messageType,     Std_MessageResultType* messageResult )</pre>	
<b>Service ID [hex]</b>	0x05	
<b>Sync/Async</b>	Synchronous	
<b>Reentrancy</b>	Reentrant	
<b>Parameters (in)</b>	buffer	Buffer allocated by the RTE, where the transformed data has to be stored by the transformer.
	bufferLength	Length of the buffer
<b>Parameters (inout)</b>	None	
<b>Parameters (out)</b>	messageType	Canonical representation of the message type (extracted from the transformers protocol header).
	messageResult	Canonical representation of the message result type (extracted from the transformers protocol header).
<b>Return value</b>	Std_ReturnType	E_OK: Relevant protocol header fields have been extracted successfully.  E_NOT_OK: An error occurred during parsing of the SOME/IP protocol header (e.g., incorrect protocol version or insufficient buffer length (bufferLength smaller than minimal SOME/IPheader length))
<b>Description</b>	Function to extract the relevant SOME/IP protocol header fields of the message and the type of the message result. - At the time being, this is limited to the types used for C/S communication (i.e., REQUEST and RESPONSE and OK and ERROR).	
<b>Available via</b>	SomeIpXf.h	

](SRS\_Xfrm\_00002)

**[SWS\_SomeIpXf\_00296]** [The function `SomeIpXf_ExtractProtocolHeaderFields` specified in [\[SWS\\_SomeIpXf\\_91001\]](#) shall extract the type of a message and the type of the message result from the SOME/IP protocol header and provide this information in a canonical representation via its output arguments.](SRS\_Xfrm\_00002)

**[SWS\_SomeIpXf\_00297]** [The function `SomeIpXf_ExtractProtocolHeaderFields` specified in [\[SWS\\_SomeIpXf\\_91001\]](#) shall check whether the provided `bufferLength` is larger or equal than the size of the protocol header processed by the SOME/IP transformer (i.e., 8 bytes). – If this is not the case, `E_NOT_OK` shall be returned. Neither `messageType` nor `messageResult` shall be modified in this case.](SRS\_Xfrm\_00002)

**[SWS\_SomeIpXf\_00298]** [The function `SomeIpXf_ExtractProtocolHeaderFields` specified in [\[SWS\\_SomeIpXf\\_91001\]](#) shall check whether the value of the Protocol Version field (see [\[PRS\\_SOMEIP\\_00052\]](#)) is equal to the value defined by [\[PRS\\_SOMEIP\\_00051\]](#). – If this is not the case, `E_NOT_OK` shall be returned. Neither `messageType` nor `messageResult` shall be modified in this case.](SRS\_Xfrm\_00002)

**[SWS\_SomeIpXf\_00299]** [The function `SomeIpXf_ExtractProtocolHeaderFields` specified in [\[SWS\\_SomeIpXf\\_91001\]](#) shall check whether the value of the

Message Type field (see [PRS\_SOMEIP\_00055]) is equal REQUEST, RESPONSE, or ERROR. – If this is not the case, E\_NOT\_OK shall be returned. Neither `messageType` nor `messageResult` shall be modified in this case. (SRS\_Xfrm\_00002)

**[SWS\_SomIpXf\_00301]** [The function `SomeIpXf_ExtractProtocolHeaderFields` specified in [SWS\_SomIpXf\_91001] shall return E\_OK in all other cases.] (SRS\_Xfrm\_00002)

**[SWS\_SomIpXf\_00302]** [The function `SomeIpXf_ExtractProtocolHeaderFields` specified in [SWS\_SomIpXf\_91001] shall set `messageType` to `STD_MESSAGE_TYPE_REQUEST` in case the value of the Message Type field (see [PRS\_SOMEIP\_00055]) is equal REQUEST.] (SRS\_Xfrm\_00002)

**[SWS\_SomIpXf\_00303]** [The function `SomeIpXf_ExtractProtocolHeaderFields` specified in [SWS\_SomIpXf\_91001] shall set `messageType` to `STD_MESSAGE_TYPE_RESULT` in case the value of the Message Type field (see [PRS\_SOMEIP\_00055]) is equal RESULT or ERROR.] (SRS\_Xfrm\_00002)

**[SWS\_SomIpXf\_00304]** [The function `SomeIpXf_ExtractProtocolHeaderFields` specified in [SWS\_SomIpXf\_91001] shall set `messageResult` to `STD_MESSAGE_RESULT_ERROR` in case the value of the Message Type field (see [PRS\_SOMEIP\_00055]) is equal to ERROR or if the value of the Return Code field (see [PRS\_SOMEIP\_00058]) is different from 0.] (SRS\_Xfrm\_00002)

**[SWS\_SomIpXf\_00305]** [The function `SomeIpXf_ExtractProtocolHeaderFields` specified in [SWS\_SomIpXf\_91001] shall set `messageResult` to `STD_MESSAGE_RESULT_OK` otherwise (i.e., in case the value of the Message Type field (see [PRS\_SOMEIP\_00055]) is different from ERROR and if the value of the Return Code field (see [PRS\_SOMEIP\_00058]) is 0.) (SRS\_Xfrm\_00002)

### 8.3.2 SomIpXf\_<transformerId>

**[SWS\_SomIpXf\_00138]** [

<b>Service Name</b>	SomIpXf_<transformerId>	
<b>Syntax</b>	<pre>uint8 SomeIpXf_&lt;transformerId&gt; (     uint8* buffer,     uint32* bufferLength,     &lt;paramtype&gt; dataElement )</pre>	
<b>Service ID [hex]</b>	0x03	
<b>Sync/Async</b>	Synchronous	
<b>Reentrancy</b>	Non Reentrant	
<b>Parameters (in)</b>	dataElement	Data element which shall be transformed
<b>Parameters (inout)</b>	None	





<b>Parameters (out)</b>	buffer	Buffer allocated by the RTE, where the transformed data has to be stored by the transformer
	bufferLength	Used length of the buffer
<b>Return value</b>	uint8	0x00 (E_OK): Serialization successful 0x81 (E_SER_GENERIC_ERROR): A generic error occurred
<b>Description</b>	This function transforms a Sender/Receiver communication using the serialization of SOME/IP. It takes the data element as input and outputs a uint8 array containing the serialized data.  The length of the serialized data shall be calculated by the transformer during runtime and returned in the OUT-parameter bufferLength. It may be smaller than the maximum buffer size used by the RTE for buffer allocation.	
<b>Available via</b>	SomeIpXf.h	

]()

**[SWS\_SomeIpXf\_00228]** [In function `SomeIpXf_<transformerId>` defined in [\[SWS\\_SomeIpXf\\_00138\]](#)

- `paramType` is derived from `type` according to the parameter passing rules defined by the [14, SRS BSW General] (see [SRS\_BSW\_00484], [SRS\_BSW\_00485], and [SRS\_BSW\_00486]) and [13, SWS BSW General] (see [SWS\_BSW\_00186] and [SWS\_BSW\_00187]).
- `type` shall be the data type of the data element after all data conversion activities of the RTE
- `transformerId` shall be the name pattern for the transformer specified in [SWS\_Xfrm\_00062] ([3, ASWS Transformer General])

]()

This function specified in [\[SWS\\_SomeIpXf\\_00138\]](#) exists for each transformed Sender/Receiver communication which uses the SOME/IP serialization.

**[SWS\_SomeIpXf\_00139]** [The function `SomeIpXf_<transformerId>` specified in [\[SWS\\_SomeIpXf\\_00138\]](#) shall exist for the first reference in the list of ordered references `transformer` from a `DataTransformation` to a `TransformationTechnology` if the `DataTransformation` is referenced by an `ISignal` in the role `dataTransformation` where the `ISignal` references a `SystemSignal` which is referenced by `SenderReceiverToSignalMapping`.]()

**[SWS\_SomeIpXf\_00140]** [The function `SomeIpXf_<transformerId>` specified in [\[SWS\\_SomeIpXf\\_00138\]](#) shall serialize primitive or complex data elements of Sender/Receiver communication into a linear byte array representation using the SOME/IP serialization.]()

**[SWS\_SomeIpXf\_00214]** [After serialization of the data, the function `SomeIpXf_<transformerId>` specified in [\[SWS\\_SomeIpXf\\_00138\]](#) shall increment the Session Handling ID counter assigned to `<transformerId>` if `sessionHandlingSR` is set to `sessionHandlingActive`.]()

[SWS\_SomeIpXf\_00215] [When the Session Handling ID counter assigned to <transformerId> is 0xFFFF and gets incremented, it shall roll-over to 0x0001 (instead of 0x0000) if sessionHandlingSR is set to [sessionHandlingActive](#).]()

[SWS\_SomeIpXf\_00141] [

<b>Service Name</b>	SomeIpXf_<transformerId>	
<b>Syntax</b>	<pre>uint8 SomeIpXf_&lt;transformerId&gt; (     const Rte-Cs_TransactionHandleType* TransactionHandle,     uint8* buffer,     uint32* bufferLength,     [Std_ReturnType returnValue],     &lt;paramtype&gt; data_1, ...     &lt;paramtype&gt; data_n )</pre>	
<b>Service ID [hex]</b>	0x03	
<b>Sync/Async</b>	Synchronous	
<b>Reentrancy</b>	Non Reentrant	
<b>Parameters (in)</b>	TransactionHandle	Transaction handle according to [SWS_Rte_08732] (clientId and sequenceCounter) needed to differentiate between multiple requests.
	returnValue	Return value from server side for transmission to the calling client. This argument is only available for serializers of the response of a Client/Server communication if <ul style="list-style-type: none"> <li>the ClientServerOperation has at least one PossibleError defined or</li> <li>autonomous error reaction is activated</li> </ul>
	data_1	Client/Server operation argument which shall be transformed (in the same order as in the corresponding interface)
	...	...
	data_n	Client/Server operation argument which shall be transformed (in the same order as in the corresponding interface)
<b>Parameters (inout)</b>	None	
<b>Parameters (out)</b>	buffer	Buffer allocated by the RTE, where the transformed data has to be stored by the transformer
	bufferLength	Used length of the buffer
<b>Return value</b>	uint8	0x00 (E_OK): Serialization successful 0x81 (E_SER_GENERIC_ERROR): A generic error occurred
<b>Description</b>	<p>This function transforms a Client/Server communication using the serialization of SOME/IP. It takes the operation arguments and optionally the return value as input and outputs a uint8 array containing the serialized data.</p> <p>The length of the serialized data shall be calculated by the transformer during runtime and returned in the OUT-parameter bufferLength. It may be smaller than the maximum buffer size used by the RTE for buffer allocation.</p>	
<b>Available via</b>	SomeIpXf.h	

]()

[SWS\_SomeIpXf\_00229] [In function SomeIpXf\_<transformerId> defined in [\[SWS\\_SomeIpXf\\_00141\]](#)

- paramtype is derived from type according to the parameter passing rules defined by the [14, SRS BSW General] (see [SRS\_BSW\_00484], [SRS\_BSW\_

00485], and [SRS\_BSW\_00486]) and [13, SWS BSW General] (see [SWS\_BSW\_00186] and [SWS\_BSW\_00187]).

- `type` shall be the data type of the data element after all data conversion activities of the RTE
- `transformerId` shall be the name pattern for the transformer specified in [SWS\_Xfrm\_00062] ([3, ASWS Transformer General]).

]()

This function specified in [SWS\_SomelpXf\_00141] exists for the server and each client of each transformed Client/Server communication which uses the SOME/IP serialization.

It exists on both the Client and the Server but the arguments are different.

On the client it serializes the request of the Client/Server call. There, the `data_1`, ..., `data_n` arguments of the API correspond to the *IN* and *INOUT* arguments of the `ClientServerOperation`. The argument `returnValue` doesn't exist.

On the server it serializes the response of the Client/Server call. There, the `data_1`, ..., `data_n` arguments of the API correspond to the *INOUT* and *OUT* arguments of the `ClientServerOperation`. The argument `returnValue` exists here if at least one `PossibleError` is defined for the `ClientServerOperation` because the return code of the operation has to be transmitted.

[SWS\_SomelpXf\_00142] [The function `SomeIpXf_<transformerId>` specified in [SWS\_SomelpXf\_00141] shall exist for the first reference in the list of ordered references `transformer` from a `DataTransformation` to a `TransformationTechnology` if the `DataTransformation` is referenced by an `ISignal` in the role `dataTransformation` where the `ISignal` references a `SystemSignal` which is referenced by `ClientServerToSignalMapping` in the `callSignal` or `returnSignal`.]()

Due to [SWS\_SomelpXf\_00142], the API of [SWS\_SomelpXf\_00141] exists both on client and server.

[SWS\_SomelpXf\_00143] [The function `SomeIpXf_<transformerId>` [\_`<symbolSuffix>`] specified in [SWS\_SomelpXf\_00141] shall serialize all primitive or complex operation arguments and the return value (if executed on server side) of Client/Server communication into a linear byte array representation using the SOME/IP serialization.]()

[SWS\_SomelpXf\_00203] [The function `SomeIpXf_<transformerId>` [\_`<symbolSuffix>`] specified in [SWS\_SomelpXf\_00141] shall ignore all arguments `data_1`, ..., `data_n` if the return code is greater or equal to `0x80` because they are not filled with meaningful values.](SRS\_Xfrm\_00105)

[SWS\_SomelpXf\_00206] [

<b>Service Name</b>	SomeIpXf_<transformerId>	
<b>Syntax</b>	<pre>uint8 SomeIpXf_&lt;transformerId&gt; (     uint8* buffer,     uint32* bufferLength )</pre>	
<b>Service ID [hex]</b>	0x03	
<b>Sync/Async</b>	Synchronous	
<b>Reentrancy</b>	Reentrant	
<b>Parameters (in)</b>	None	
<b>Parameters (inout)</b>	None	
<b>Parameters (out)</b>	buffer	Buffer allocated by the RTE, where the transformed data has to be stored by the transformer
	bufferLength	Used length of the buffer
<b>Return value</b>	uint8	0x00 (E_OK): Serialization successful 0x81 (E_SER_GENERIC_ERROR): A generic error occurred
<b>Description</b>	<p>This function transforms an external trigger event using the serialization of SOME/IP. It takes trigger as input and outputs a uint8 array.</p> <p>The length of the transformed data shall be calculated by the transformer during runtime and returned in the OUT parameter bufferLength. It may be smaller than the maximum buffer size used by the RTE for buffer allocation.</p>	
<b>Available via</b>	SomeIpXf.h	

](SRS\_Xfrm\_00002)

[SWS\_SomeIpXf\_00230] [In function SomeIpXf\_<transformerId> defined in [SWS\_SomeIpXf\_00206]

- transformerId shall be the name pattern for the transformer specified in [SWS\_Xfrm\_00062] ([3, ASWS Transformer General]).

]()

This function specified in [SWS\_SomeIpXf\_00206] exists on the trigger source side for each transformed external trigger event which uses SOME/IP transformation.

[SWS\_SomeIpXf\_00207] [The function SomeIpXf\_<transformerId> specified in [SWS\_SomeIpXf\_00206] shall exist for the first referenced TransformationTechnology in the ordered transformerChain of a DataTransformation if the DataTransformation is referenced by an ISignal in the role dataTransformation where the ISignal references a SystemSignal which is referenced by a TriggerToSignalMapping.] (SRS\_Xfrm\_00002)

[SWS\_SomeIpXf\_00208] [The function SomeIpXf\_<transformerId> specified in [SWS\_SomeIpXf\_00206] shall serialize an external trigger event into a linear byte array representation using the SOME/IP serialization.] (SRS\_Xfrm\_00002)

As an external trigger event consists of an ISignal with length equal to zero, the serialized SOME/IP message only contains a header but no payload.

### 8.3.3 SomelpXf\_Inv\_<transformerId>

[SWS\_SomelpXf\_00144] [

<b>Service Name</b>	SomelpXf_Inv_<transformerId>	
<b>Syntax</b>	<pre>uint8 SomeIpXf_Inv_&lt;transformerId&gt; (     const uint8* buffer,     uint32 bufferSize,     &lt;type&gt;* dataElement )</pre>	
<b>Service ID [hex]</b>	0x04	
<b>Sync/Async</b>	Synchronous	
<b>Reentrancy</b>	Reentrant	
<b>Parameters (in)</b>	buffer	Buffer allocated by the RTE, where the still serialized data are stored by the Rte
	bufferLength	Used length of the buffer
<b>Parameters (inout)</b>	None	
<b>Parameters (out)</b>	dataElement	Data element which is the result of the transformation and contains the deserialized data element
<b>Return value</b>	uint8	0x00 (E_OK): Deserialization successful 0x01 (E_NO_DATA): No data available which can be deserialized 0x81 (E_SER_GENERIC_ERROR): A generic error occurred 0x87 (E_SER_WRONG_PROTOCOL_VERSION): The version of the receiving transformer didn't match the sending transformer. 0x88 (E_SER_WRONG_INTERFACE_VERSION): Interface version of serialized data is not supported. 0x89 (E_SER_MALFORMED_MESSAGE): The received message is malformed. The transformer is not able to produce an output. 0x8a (E_SER_WRONG_MESSAGE_TYPE): The received message type was not expected.
<b>Description</b>	This function deserializes a Sender/Receiver communication using the deserialization of SOME/IP. It takes the uint8 array containing the serialized data as input and outputs the original data element which will be passed to the RTE.	
<b>Available via</b>	SomelpXf.h	

]()

[SWS\_SomelpXf\_00231] [In function SomeIpXf\_Inv\_<transformerId> defined in [SWS\_SomelpXf\_00144]

- `type` shall be the data type of the data element before all data conversion activities of the RTE
- `transformerId` shall be the name pattern for the transformer specified in [SWS\_Xfrm\_00062] ([3, ASWS Transformer General]).

]()

This function specified in [SWS\_SomelpXf\_00144] exists for each transformed Sender/Receiver communication which uses the SOME/IP serialization.

[SWS\_SomelpXf\_00146] [The function SomeIpXf\_Inv\_<transformerId> specified in [SWS\_SomelpXf\_00144] shall exist for the first reference in the list of ordered references `transformer` from a [DataTransformation](#) to a [Transformation-](#)

Technology if the `DataTransformation` is referenced by an `ISignal` in the role `dataTransformation` where the `ISignal` references a `SystemSignal` which is referenced by `SenderReceiverToSignalMapping`.]()

**[SWS\_SomelpXf\_00147]** [The function `SomeIpXf_Inv_<transformerId>` specified in **[SWS\_SomelpXf\_00144]** shall deserialize a linear byte array to primitive or complex data elements of Sender/Receiver communication using the SOME/IP deserialization.]()

**[SWS\_SomelpXf\_00264]** [If `SomeIpXf_Inv_<transformerId>` specified in **[SWS\_SomelpXf\_00144]** is called with `buffer` equal to `NULL_PTR` and `bufferLength` equal to 0, the output buffer `buffer` shall not be changed and `SomeIpXf_Inv_<transformerId>` shall return with `E_NO_DATA`.]([SRS\\_Xfrm\\_00001](#), [SRS\\_Xfrm\\_00004](#))

**[SWS\_SomelpXf\_00145]** [

<b>Service Name</b>	SomeIpXf_Inv_<transformerId>	
<b>Syntax</b>	<pre>uint8 SomeIpXf_Inv_&lt;transformerId&gt; (     Rte-Cs-TransactionHandleType* TransactionHandle,     const uint8* buffer,     uint32 bufferLength,     [Std_ReturnType* returnValue],     [&lt;paramtype&gt; data] )</pre>	
<b>Service ID [hex]</b>	0x04	
<b>Sync/Async</b>	Synchronous	
<b>Reentrancy</b>	Reentrant	
<b>Parameters (in)</b>	buffer	Buffer allocated by the RTE, where the still serialized data are stored by the Rte
	bufferLength	Used length of the buffer
<b>Parameters (inout)</b>	None	
<b>Parameters (out)</b>	TransactionHandle	Transaction handle according to <b>[SWS_Rte_08732]</b> (clientId and sequenceCounter) needed to differentiate between multiple requests.
	returnValue	Return value from server side for transmission to the calling client. This argument is only available for serializers of the response of a Client/Server communication if <ul style="list-style-type: none"> <li>the ClientServerOperation has at least one PossibleError defined or</li> <li>autonomous error reaction is activated</li> </ul>
	data	Client/Server operation argument which shall be transformed (in the same order as in the corresponding interface)
<b>Return value</b>	uint8	0x00 (E_OK): Deserialization successful 0x01 (E_NO_DATA): No data available which can be deserialized 0x81 (E_SER_GENERIC_ERROR): A generic error occurred 0x87 (E_SER_WRONG_PROTOCOL_VERSION): The version of the receiving transformer didn't match the sending transformer. 0x88 (E_SER_WRONG_INTERFACE_VERSION): Interface





△

		<p>△ version of serialized data is not supported. 0x89 (E_SER_MALFORMED_MESSAGE): The received message is malformed. The transformer is not able to produce an output. 0x8a (E_SER_WRONG_MESSAGE_TYPE): The received message type was not expected.</p>
<b>Description</b>	This function deserializes a Client/Server communication using the deserialization of SOME/IP. It takes the uint8 array containing the serialized data as input and outputs the return value of the server runnable and the operation arguments which have to be passed from the server to the client.	
<b>Available via</b>	SomeIpXf.h	

]()

**[SWS\_SomeIpXf\_00232]** [In function `SomeIpXf_Inv_<transformerId>` defined in [\[SWS\\_SomeIpXf\\_00145\]](#)

- `paramType` is derived from `type` according to the parameter passing rules defined by the [14, SRS BSW General] (see [SRS\_BSW\_00484], [SRS\_BSW\_00485], and [SRS\_BSW\_00486]) and [13, SWS BSW General] (see [SWS\_BSW\_00186] and [SWS\_BSW\_00187]).
- `type` shall be the data type of the data element before all data conversion activities of the RTE
- `transformerId` shall be the name pattern for the transformer specified in [SWS\_Xfrm\_00062] ([3, ASWS Transformer General]).

]()

This function specified in [\[SWS\\_SomeIpXf\\_00145\]](#) exists for the server and each client of each transformed Client/Server communication which uses the SOME/IP serialization.

It exists on both the Client and the Server but the arguments are different.

On the server it deserializes the request of the Client/Server call. There, the `data_1`, ..., `data_n` arguments of the API correspond to the *IN* and *INOUT* arguments of the [ClientServerOperation](#). The argument `returnValue` doesn't exist.

On the client it deserializes the response of the Client/Server call. There, the `data_1`, ..., `data_n` arguments of the API correspond to the *INOUT* and *OUT* arguments of the [ClientServerOperation](#). The argument `returnValue` exists here if at least one `PossibleError` is defined for the [ClientServerOperation](#) because the return code of the operation has to be transmitted

**[SWS\_SomeIpXf\_00148]** [

The function `SomeIpXf_Inv_<transformerId>` specified in [\[SWS\\_SomeIpXf\\_00145\]](#) shall exist for the first reference in the list of ordered references `transformer` from a [DataTransformation](#) to a [TransformationTechnology](#) if the [DataTransformation](#) is referenced by an [ISignal](#) in the

role `dataTransformation` where the `ISignal` references a `SystemSignal` which is referenced by `ClientServerToSignalMapping` in the `callSignal` or `returnSignal`.]()

Due to [SWS\_SomelpXf\_00148], the API of [SWS\_SomelpXf\_00145] exists both on client and server.

**[SWS\_SomelpXf\_00149]** [The function `SomeIpXf_Inv_<transformerId>` specified in [SWS\_SomelpXf\_00145] shall deserialize a linear byte array which contains primitive or complex operation arguments and the return value (if executed on client side) of Client/Server communication using the SOME/IP deserialization.]()

**[SWS\_SomelpXf\_00265]** [If `SomeIpXf_Inv_<transformerId>` specified in [SWS\_SomelpXf\_00145] is called with `buffer` equal to `NULL_PTR` and `bufferLength` equal to 0, the output buffer `buffer` shall not be changed and `SomeIpXf_Inv_<transformerId>` shall return with `E_NO_DATA`.](SRS\_Xfrm\_00001, SRS\_Xfrm\_00004)

**[SWS\_SomelpXf\_00209]** [

<b>Service Name</b>	SomelpXf_Inv_<transformerId>	
<b>Syntax</b>	<pre>uint8 SomeIpXf_Inv_&lt;transformerId&gt; (     const uint8* buffer,     uint32 bufferLength )</pre>	
<b>Service ID [hex]</b>	0x04	
<b>Sync/Async</b>	Synchronous	
<b>Reentrancy</b>	Reentrant	
<b>Parameters (in)</b>	buffer	Buffer allocated by the RTE, where the still serialized data are stored by the Rte
	bufferLength	Used length of the buffer
<b>Parameters (inout)</b>	None	
<b>Parameters (out)</b>	None	
<b>Return value</b>	uint8	0x00 (E_OK): Deserialization successful 0x01 (E_NO_DATA): No data available which can be deserialized 0x81 (E_SER_GENERIC_ERROR): A generic error occurred 0x87 (E_SER_WRONG_PROTOCOL_VERSION): The version of the receiving transformer didn't match the sending transformer. 0x88 (E_SER_WRONG_INTERFACE_VERSION): Interface version of serialized data is not supported. 0x89 (E_SER_MALFORMED_MESSAGE): The received message is malformed. The transformer is not able to produce an output. 0x8a (E_SER_WRONG_MESSAGE_TYPE): The received message type was not expected.
<b>Description</b>	This function deserializes an external trigger event using the deserialization of SOME/IP.	
<b>Available via</b>	SomelpXf.h	

] (SRS\_Xfrm\_00002)

**[SWS\_SomelpXf\_00233]** [In function `SomeIpXf_Inv_<transformerId>` defined in [SWS\_SomelpXf\_00209]

- `transformerId` shall be the name pattern for the transformer specified in [SWS\_Xfrm\_00062] ([3, ASWS Transformer General]).

]()

This function specified in [SWS\_SomelpXf\_00209] exists on the trigger sink side for each transformed external trigger event which uses SOME/IP transformation.

[SWS\_SomelpXf\_00210] [The function `SomeIpXf_Inv_<transformerId>` specified in [SWS\_SomelpXf\_00209] shall exist for the first referenced `TransformationTechnology` in the ordered `transformerChain` of a `DataTransformation` if the `DataTransformation` is referenced by an `ISignal` in the role `dataTransformation` where the `ISignal` references a `SystemSignal` which is referenced by a `TriggerToSignalMapping`.] (*SRS\_Xfrm\_00002*)

[SWS\_SomelpXf\_00211] [The function `SomeIpXf_Inv_<transformerId>` specified in [SWS\_SomelpXf\_00209] shall deserialize a linear byte array to an external trigger event using the SOME/IP deserialization.] (*SRS\_Xfrm\_00002*)

[SWS\_SomelpXf\_00266] [If `SomeIpXf_Inv_<transformerId>` specified in [SWS\_SomelpXf\_00209] is called with `buffer` equal to `NULL_PTR` and `bufferLength` equal to 0, the output buffer `buffer` shall not be changed and `SomeIpXf_Inv_<transformerId>` shall return with `E_NO_DATA`.] (*SRS\_Xfrm\_00001, SRS\_Xfrm\_00004*)

As an external trigger event consists of an `ISignal` with length equal to zero, the serialized SOME/IP message only contains a header but no payload.

### 8.3.4 SomelpXf\_Init

[SWS\_SomelpXf\_00181] [

<b>Service Name</b>	SomelpXf_Init	
<b>Syntax</b>	<pre>void SomeIpXf_Init (     const SomeIpXf_ConfigType* config )</pre>	
<b>Service ID [hex]</b>	0x01	
<b>Sync/Async</b>	Synchronous	
<b>Reentrancy</b>	Reentrant	
<b>Parameters (in)</b>	config	Pointer to the transformer's configuration data.
<b>Parameters (inout)</b>	None	
<b>Parameters (out)</b>	None	
<b>Return value</b>	None	
<b>Description</b>	This service initializes the transformer for the further processing.	
<b>Available via</b>	SomelpXf.h	

] (*SRS\_BSW\_00407, SRS\_BSW\_00411*)

### 8.3.5 SomelpXf\_DeInit

[SWS\_SomelpXf\_00182] [

<b>Service Name</b>	SomelpXf_DeInit
<b>Syntax</b>	<pre>void SomeIpXf_DeInit (     void )</pre>
<b>Service ID [hex]</b>	0x02
<b>Sync/Async</b>	Synchronous
<b>Reentrancy</b>	Reentrant
<b>Parameters (in)</b>	None
<b>Parameters (inout)</b>	None
<b>Parameters (out)</b>	None
<b>Return value</b>	None
<b>Description</b>	This service deinitializes the transformer.
<b>Available via</b>	SomelpXf.h

]([SRS\\_BSW\\_00407](#), [SRS\\_BSW\\_00411](#))

### 8.3.6 SomelpXf\_GetVersionInfo

[SWS\_SomelpXf\_00180] [

<b>Service Name</b>	SomelpXf_GetVersionInfo
<b>Syntax</b>	<pre>void SomeIpXf_GetVersionInfo (     Std_VersionInfoType* VersionInfo )</pre>
<b>Service ID [hex]</b>	0x00
<b>Sync/Async</b>	Synchronous
<b>Reentrancy</b>	Reentrant
<b>Parameters (in)</b>	None
<b>Parameters (inout)</b>	None
<b>Parameters (out)</b>	VersionInfo   Pointer to where to store the version information of this module.
<b>Return value</b>	None
<b>Description</b>	This service returns the version information of the called transformer module.
<b>Available via</b>	SomelpXf.h

]([SRS\\_BSW\\_00407](#), [SRS\\_BSW\\_00411](#))

## 8.4 Callback notifications

There are no callback notifications.

## 8.5 Scheduled functions

SOME/IP Transformer has no scheduled functions

## 8.6 Expected interfaces

There are no expected interfaces.

## 9 Sequence diagrams

There are no sequence diagrams applicable to SOME/IP Transformer.

## 10 Configuration specification

There is no module specific configuration available to the SOME/IP Transformer. The EcuC defined in [3, ASWS Transformer General] shall be used.

**[SWS\_SomeIpXf\_00185]** [The `apiServicePrefix` of the SOME/IP transformer's EcuC shall be set to `SomeIpXf.`] ([SRS\\_BSW\\_00159](#))

## A Referenced Meta Classes

For the sake of completeness, this chapter contains a set of class tables representing meta-classes mentioned in the context of this document but which are not contained directly in the scope of describing specific meta-model semantics.

<b>Class</b>	<b>ApplicationArrayType</b>			
<b>Package</b>	M2::AUTOSARTemplates::SWComponentTemplate::Datatype::Datatypes			
<b>Note</b>	An application data type which is an array, each element is of the same application data type. <b>Tags:</b> atp.recommendedPackage=ApplicationDataTypes			
<b>Base</b>	ARElement, ARObject, ApplicationCompositeDataType, ApplicationDataType, AtpBlueprint, AtpBlueprintable, AtpClassifier, AtpType, AutosarDataType, CollectableElement, Identifiable, MultilanguageReferrable, PackageableElement, Referrable			
<b>Attribute</b>	<b>Type</b>	<b>Mult.</b>	<b>Kind</b>	<b>Note</b>
dynamicArraySizeProfile	String	0..1	attr	Specifies the profile which the array will follow if it is a variable size array.
element	ApplicationArrayElement	0..1	aggr	This association implements the concept of an array element. That is, in some cases it is necessary to be able to identify single array elements, e.g. as input values for an interpolation routine.

**Table A.1: ApplicationArrayType**

<b>Class</b>	<b>ApplicationError</b>			
<b>Package</b>	M2::AUTOSARTemplates::SWComponentTemplate::PortInterface			
<b>Note</b>	This is a user-defined error that is associated with an element of an AUTOSAR interface. It is specific for the particular functionality or service provided by the AUTOSAR software component.			
<b>Base</b>	ARObject, Identifiable, MultilanguageReferrable, Referrable			
<b>Attribute</b>	<b>Type</b>	<b>Mult.</b>	<b>Kind</b>	<b>Note</b>
errorCode	Integer	0..1	attr	The RTE generator is forced to assign this value to the corresponding error symbol. Note that for error codes certain ranges are predefined (see RTE specification).

**Table A.2: ApplicationError**

<b>Class</b>	<b>ApplicationPrimitiveDataType</b>			
<b>Package</b>	M2::AUTOSARTemplates::SWComponentTemplate::Datatype::Datatypes			
<b>Note</b>	A primitive data type defines a set of allowed values. <b>Tags:</b> atp.recommendedPackage=ApplicationDataTypes			
<b>Base</b>	ARElement, ARObject, ApplicationDataType, AtpBlueprint, AtpBlueprintable, AtpClassifier, AtpType, AutosarDataType, CollectableElement, Identifiable, MultilanguageReferrable, PackageableElement, Referrable			
<b>Attribute</b>	<b>Type</b>	<b>Mult.</b>	<b>Kind</b>	<b>Note</b>
–	–	–	–	–

**Table A.3: ApplicationPrimitiveDataType**



<b>Class</b>	<b>ArgumentDataPrototype</b>			
<b>Package</b>	M2::AUTOSARTemplates::SWComponentTemplate::PortInterface			
<b>Note</b>	An argument of an operation, much like a data element, but also carries direction information and is owned by a particular ClientServerOperation.			
<b>Base</b>	<i>ARObject, AtpFeature, AtpPrototype, AutosarDataPrototype, DataPrototype, Identifiable, Multilanguage Referrable, Referrable</i>			
<b>Attribute</b>	<b>Type</b>	<b>Mult.</b>	<b>Kind</b>	<b>Note</b>
direction	ArgumentDirection Enum	0..1	attr	This attribute specifies the direction of the argument prototype.
serverArgument ImplPolicy	ServerArgumentImpl PolicyEnum	0..1	attr	This defines how the argument type of the servers RunnableEntity is implemented.  If the attribute is not defined this has the same semantics as if the attribute is set to the value useArgumentType for primitive arguments and structures.

**Table A.4: ArgumentDataPrototype**

<b>Enumeration</b>	<b>ArraySizeSemanticsEnum</b>
<b>Package</b>	M2::AUTOSARTemplates::CommonStructure::ImplementationDataTypes
<b>Note</b>	This type controls how the information about the number of elements in an ApplicationArrayDataType is to be interpreted.
<b>Literal</b>	<b>Description</b>
fixedSize	This means that the ApplicationArrayDataType will always have a fixed number of elements. <b>Tags:</b> atp.EnumerationLiteralIndex=0
variableSize	This implies that the actual number of elements in the ApplicationArrayDataType might vary at run-time. The value of arraySize represents the maximum number of elements in the array. <b>Tags:</b> atp.EnumerationLiteralIndex=1

**Table A.5: ArraySizeSemanticsEnum**

<b>Class</b>	<b>AutosarDataType</b> (abstract)			
<b>Package</b>	M2::AUTOSARTemplates::SWComponentTemplate::Datatype::Datatypes			
<b>Note</b>	Abstract base class for user defined AUTOSAR data types for software.			
<b>Base</b>	<i>ARElement, ARObject, AtpClassifier, AtpType, CollectableElement, Identifiable, Multilanguage Referrable, PackageableElement, Referrable</i>			
<b>Subclasses</b>	<i>AbstractImplementationDataType, ApplicationDataType</i>			
<b>Attribute</b>	<b>Type</b>	<b>Mult.</b>	<b>Kind</b>	<b>Note</b>
swDataDef Props	SwDataDefProps	0..1	aggr	The properties of this AutosarDataType.

**Table A.6: AutosarDataType**

<b>Class</b>	<b>BaseType</b> (abstract)			
<b>Package</b>	M2::MSR::AsamHdo::BaseTypes			
<b>Note</b>	This abstract meta-class represents the ability to specify a platform dependant base type.			
<b>Base</b>	<i>ARElement, ARObject, CollectableElement, Identifiable, MultilanguageReferrable, Packageable Element, Referrable</i>			





<b>Class</b>	<b>BaseType</b> (abstract)			
<b>Subclasses</b>	<a href="#">SwBaseType</a>			
<b>Attribute</b>	<b>Type</b>	<b>Mult.</b>	<b>Kind</b>	<b>Note</b>
baseType Definition	BaseTypeDefinition	1	aggr	This is the actual definition of the base type. <b>Tags:</b> xml.roleElement=false xml.roleWrapperElement=false xml.sequenceOffset=20 xml.typeElement=false xml.typeWrapperElement=false

**Table A.7: BaseType**

<b>Class</b>	<b>BaseTypeDirectDefinition</b>			
<b>Package</b>	M2::MSR::AsamHdo::BaseTypes			
<b>Note</b>	This BaseType is defined directly (as opposite to a derived BaseType)			
<b>Base</b>	<i>ARObject, BaseTypeDefinition</i>			
<b>Attribute</b>	<b>Type</b>	<b>Mult.</b>	<b>Kind</b>	<b>Note</b>
baseType Encoding	BaseTypeEncoding String	0..1	attr	This specifies, how an object of the current BaseType is encoded, e.g. in an ECU within a message sequence. <b>Tags:</b> xml.sequenceOffset=90
baseTypeSize	PositiveInteger	0..1	attr	Describes the length of the data type specified in the container in bits. <b>Tags:</b> xml.sequenceOffset=70
byteOrder	<a href="#">ByteOrderEnum</a>	0..1	attr	This attribute specifies the byte order of the base type. <b>Tags:</b> xml.sequenceOffset=110
memAlignment	PositiveInteger	0..1	attr	This attribute describes the alignment of the memory object in bits. E.g. "8" specifies, that the object in question is aligned to a byte while "32" specifies that it is aligned four byte. If the value is set to "0" the meaning shall be interpreted as "unspecified". <b>Tags:</b> xml.sequenceOffset=100
native Declaration	NativeDeclarationString	0..1	attr	This attribute describes the declaration of such a base type in the native programming language, primarily in the Programming language C. This can then be used by a code generator to include the necessary declarations into a header file. For example BaseType with shortName: "MyUnsignedInt" native Declaration: "unsigned short" Results in typedef unsigned short MyUnsignedInt; If the attribute is not defined the referring Implementation DataTypes will not be generated as a typedef by RTE. If a nativeDeclaration type is given it shall fulfill the characteristic given by basetypeEncoding and baseType Size. This is required to ensure the consistent handling and interpretation by software components, RTE, COM and MCM systems. <b>Tags:</b> xml.sequenceOffset=120

**Table A.8: BaseTypeDirectDefinition**

<b>Class</b>	<b>ClientServerInterface</b>			
<b>Package</b>	M2::AUTOSARTemplates::SWComponentTemplate::PortInterface			
<b>Note</b>	A client/server interface declares a number of operations that can be invoked on a server by a client. <b>Tags:</b> atp.recommendedPackage=PortInterfaces			
<b>Base</b>	<i>ARElement, ARObject, AtpBlueprint, AtpBlueprintable, AtpClassifier, AtpType, CollectableElement, Identifiable, MultilanguageReferrable, PackageableElement, PortInterface, Referrable</i>			
<b>Attribute</b>	<b>Type</b>	<b>Mult.</b>	<b>Kind</b>	<b>Note</b>
operation	<a href="#">ClientServerOperation</a>	*	aggr	ClientServerOperation(s) of this ClientServerInterface. <b>Stereotypes:</b> atpVariation <b>Tags:</b> vh.latestBindingTime=blueprintDerivationTime
possibleError	<a href="#">ApplicationError</a>	*	aggr	Application errors that are defined as part of this interface.

**Table A.9: ClientServerInterface**

<b>Class</b>	<b>ClientServerOperation</b>			
<b>Package</b>	M2::AUTOSARTemplates::SWComponentTemplate::PortInterface			
<b>Note</b>	An operation declared within the scope of a client/server interface.			
<b>Base</b>	<i>ARObject, AtpClassifier, AtpFeature, AtpStructureElement, Identifiable, MultilanguageReferrable, Referrable</i>			
<b>Attribute</b>	<b>Type</b>	<b>Mult.</b>	<b>Kind</b>	<b>Note</b>
argument (ordered)	<a href="#">ArgumentDataPrototype</a>	*	aggr	An argument of this ClientServerOperation <b>Stereotypes:</b> atpVariation <b>Tags:</b> vh.latestBindingTime=blueprintDerivationTime
diagArgIntegrity	Boolean	0..1	attr	This attribute shall only be used in the implementation of diagnostic routines to support the case where input and output arguments are allocated in a shared buffer and might unintentionally overwrite input arguments by tentative write operations to output arguments.  This situation can happen during sliced execution or while output parameters are arrays (call by reference). The value true means that the ClientServerOperation is aware of the usage of a shared buffer and takes precautions to avoid unintentional overwrite of input arguments.  If the attribute does not exist or is set to false the Client ServerOperation does not have to consider the usage of a shared buffer.
possibleError	<a href="#">ApplicationError</a>	*	ref	Possible errors that may be raised by the referring operation.

**Table A.10: ClientServerOperation**

<b>Class</b>	<b>ClientServerToSignalMapping</b>			
<b>Package</b>	M2::AUTOSARTemplates::SystemTemplate::DataMapping			
<b>Note</b>	This element maps the ClientServerOperation to call- and return-SystemSignals.			
<b>Base</b>	<i>ARObject, DataMapping</i>			
<b>Attribute</b>	<b>Type</b>	<b>Mult.</b>	<b>Kind</b>	<b>Note</b>
callSignal	<a href="#">SystemSignal</a>	1	ref	Reference to the callSignal to which the IN and INOUT ArgumentDataPrototypes are mapped.





Class	ClientServerToSignalMapping			
clientServerOperation	<a href="#">ClientServerOperation</a>	1	iref	Reference to a ClientServerOperation, which is mapped to a call SystemSignal and a return SystemSignal. <b>InstanceRef implemented by:</b> OperationInSystemInstanceRef
returnSignal	<a href="#">SystemSignal</a>	0..1	ref	Reference to the returnSignal to which the OUT and INOUT ArgumentDataPrototypes are mapped. <b>Tags:</b> atp.Status=shallBecomeMandatory

**Table A.11: ClientServerToSignalMapping**

Class	DataPrototype (abstract)			
Package	M2::AUTOSARTemplates::SWComponentTemplate::Datatype::DataPrototypes			
Note	Base class for prototypical roles of any data type.			
Base	ARObject, AtpFeature, AtpPrototype, <a href="#">Identifiable</a> , MultilanguageReferrable, Referrable			
Subclasses	ApplicationCompositeElementDataPrototype, AutosarDataPrototype			
Attribute	Type	Mult.	Kind	Note
swDataDefProps	<a href="#">SwDataDefProps</a>	0..1	aggr	This property allows to specify data definition properties which apply on data prototype level.

**Table A.12: DataPrototype**

Class	DataTransformation			
Package	M2::AUTOSARTemplates::SystemTemplate::Transformer			
Note	A DataTransformation represents a transformer chain. It is an ordered list of transformers.			
Base	ARObject, <a href="#">Identifiable</a> , MultilanguageReferrable, Referrable			
Attribute	Type	Mult.	Kind	Note
dataTransformationKind	DataTransformationKind Enum	0..1	attr	This attribute controls the kind of DataTransformation to be applied.
executeDespiteDataUnavailability	Boolean	1	attr	Specifies whether the transformer chain is executed even if no input data are available.
transformerChain (ordered)	<a href="#">TransformationTechnology</a>	1..*	ref	This attribute represents the definition of a chain of transformers that are supposed to be executed according to the order of being referenced from DataTransformation.

**Table A.13: DataTransformation**

Enumeration	DataTransformationErrorHandlingEnum			
Package	M2::AUTOSARTemplates::SWComponentTemplate::SwcInternalBehavior::PortAPIOptions			
Note	This enumeration defines different ways how a RunnableEntity shall handle transformer errors.			
Literal	Description			
noTransformerErrorHandling	A runnable does not handle transformer errors. <b>Tags:</b> atp.EnumerationLiteralIndex=0			
transformerErrorHandling	The runnable implements the handling of transformer errors. <b>Tags:</b> atp.EnumerationLiteralIndex=1			

**Table A.14: DataTransformationErrorHandlingEnum**

<b>Class</b>	<b>EcucModuleDef</b>			
<b>Package</b>	M2::AUTOSARTemplates::ECUCParameterDefTemplate			
<b>Note</b>	Used as the top-level element for configuration definition for Software Modules, including BSW and RTE as well as ECU Infrastructure. <b>Tags:</b> atp.recommendedPackage=EcucModuleDefs			
<b>Base</b>	<i>ARElement, ARObject, AtpBlueprint, AtpBlueprintable, AtpDefinition, CollectableElement, EcucDefinitionElement, Identifiable, MultilanguageReferrable, PackageableElement, Referrable</i>			
<b>Attribute</b>	<b>Type</b>	<b>Mult.</b>	<b>Kind</b>	<b>Note</b>
apiServicePrefix	CIdentifier	0..1	attr	For CDD modules this attribute holds the apiService Prefix.  The shortName of the module definition of a Complex Driver is always "Cdd". Therefore for CDD modules the module apiServicePrefix is described with this attribute.
container	EcucContainerDef	*	aggr	Aggregates the top-level container definitions of this specific module definition.  <b>Stereotypes:</b> atpSplitable <b>Tags:</b> atp.Splitkey=container.shortName xml.sequenceOffset=11
postBuildVariant Support	Boolean	0..1	attr	Indicates if a module supports different post-build variants (previously known as post-build selectable configuration sets). TRUE means yes, FALSE means no.
refinedModule Def	<a href="#">EcucModuleDef</a>	0..1	ref	Optional reference from the Vendor Specific Module Definition to the Standardized Module Definition it refines. In case this EcucModuleDef has the category STANDARDIZED_MODULE_DEFINITION this reference shall not be provided. In case this EcucModuleDef has the category VENDOR_SPECIFIC_MODULE_DEFINITION this reference is mandatory.  <b>Stereotypes:</b> atpUriDef
supported ConfigVariant	EcucConfiguration VariantEnum	*	attr	Specifies which ConfigurationVariants are supported by this software module. This attribute is optional if the EcucModuleDef has the category STANDARDIZED_MODULE_DEFINITION. If the category attribute of the EcucModuleDef is set to VENDOR_SPECIFIC_MODULE_DEFINITION then this attribute is mandatory.

**Table A.15: EcucModuleDef**

<b>Class</b>	<b>ISignal</b>
<b>Package</b>	M2::AUTOSARTemplates::SystemTemplate::Fibex::FibexCore::CoreCommunication
<b>Note</b>	Signal of the Interaction Layer. The RTE supports a "signal fan-out" where the same System Signal is sent in different SignallPdus to multiple receivers.  To support the RTE "signal fan-out" each SignallPdu contains ISignals. If the same System Signal is to be mapped into several SignallPdus there is one ISignal needed for each ISignalToIPduMapping.  ISignals describe the Interface between the Precompile configured RTE and the potentially Postbuild configured Com Stack (see ECUC Parameter Mapping).  In case of the SystemSignalGroup an ISignal shall be created for each SystemSignal contained in the SystemSignalGroup.  <b>Tags:</b> atp.recommendedPackage=ISignals
<b>Base</b>	<i>ARObject, CollectableElement, FibexElement, Identifiable, MultilanguageReferrable, PackageableElement, Referrable</i>





Class	ISignal			
Attribute	Type	Mult.	Kind	Note
data Transformation	<a href="#">DataTransformation</a>	0..1	ref	Optional reference to a DataTransformation which represents the transformer chain that is used to transform the data that shall be placed inside this ISignal.  <b>Stereotypes:</b> atpSplitable; atpVariation <b>Tags:</b> atp.Splitkey=dataTransformation.dataTransformation, dataTransformation.variationPoint.shortLabel vh.latestBindingTime=codeGenerationTime
dataTypePolicy	DataTypePolicyEnum	1	attr	With the aggregation of SwDataDefProps an ISignal specifies how it is represented on the network. This representation follows a particular policy. Note that this causes some redundancy which is intended and can be used to support flexible development methodology as well as subsequent integrity checks.  If the policy "networkRepresentationFromComSpec" is chosen the network representation from the ComSpec that is aggregated by the PortPrototype shall be used. If the "override" policy is chosen the requirements specified in the PortInterface and in the ComSpec are not fulfilled by the networkRepresentationProps. In case the System Description doesn't use a complete Software Component Description (VFB View) the "legacy" policy can be chosen.
initValue	ValueSpecification	0..1	aggr	Optional definition of a ISignal's initValue in case the System Description doesn't use a complete Software Component Description (VFB View). This supports the inclusion of legacy system signals.  This value can be used to configure the Signal's "Init Value".  If a full DataMapping exist for the SystemSignal this information may be available from a configured Sender ComSpec and ReceiverComSpec. In this case the initvalues in SenderComSpec and/or ReceiverComSpec override this optional value specification. Further restrictions apply from the RTE specification.
iSignalProps	ISignalProps	0..1	aggr	Additional optional ISignal properties that may be stored in different files.  <b>Stereotypes:</b> atpSplitable <b>Tags:</b> atp.Splitkey=iSignalProps
iSignalType	ISignalTypeEnum	0..1	attr	This attribute defines whether this iSignal is an array that results in a UINT8_N / UINT8_DYN ComSignalType in the COM configuration or a primitive type.
length	Integer	1	attr	Size of the signal in bits. The size needs to be derived from the mapped VariableDataPrototype according to the mapping of primitive DataTypes to BaseType as used in the RTE. Indicates maximum size for dynamic length signals.  The ISignal length of zero bits is allowed.
network Representation Props	<a href="#">SwDataDefProps</a>	0..1	aggr	Specification of the actual network representation. The usage of SwDataDefProps for this purpose is restricted to the attributes compuMethod and baseType. The optional baseType attributes "memAllignment" and "byteOrder" shall not be used.





Class	ISignal			
				<p>The attribute "dataTypePolicy" in the SystemTemplate element defines whether this network representation shall be ignored and the information shall be taken over from the network representation of the ComSpec.</p> <p>If "override" is chosen by the system integrator the network representation can violate against the requirements defined in the PortInterface and in the network representation of the ComSpec.</p> <p>In case that the System Description doesn't use a complete Software Component Description (VFB View) this element is used to configure "ComSignalDataInvalid Value" and the Data Semantics.</p>
systemSignal	<a href="#">SystemSignal</a>	1	ref	Reference to the System Signal that is supposed to be transmitted in the ISignal.
timeout Substitution Value	ValueSpecification	0..1	aggr	Defines and enables the ComTimeoutSubstitution for this ISignal.
transformation ISignalProps	<a href="#">TransformationISignal Props</a>	*	aggr	A transformer chain consists of an ordered list of transformers. The ISignal specific configuration properties for each transformer are defined in the TransformationISignalProps class. The transformer configuration properties that are common for all ISignals are described in the TransformationTechnology class.

**Table A.16: ISignal**

<b>Class</b>	<b>Identifiable</b> (abstract)
<b>Package</b>	M2::AUTOSARTemplates::GenericStructure::GeneralTemplateClasses::Identifiable
<b>Note</b>	Instances of this class can be referred to by their identifier (within the namespace borders). In addition to this, Identifiables are objects which contribute significantly to the overall structure of an AUTOSAR description. In particular, Identifiables might contain Identifiables.
<b>Base</b>	<i>ARObject, MultilanguageReferrable, Referrable</i>
<b>Subclasses</b>	ARPpackage, <i>AbstractDolpLogicAddressProps, AbstractEvent, AbstractImplementationDataTypeElement, AbstractSecurityEventFilter, AbstractSecurityIdsmInstanceFilter, AbstractServiceInstance, Application Endpoint, ApplicationError, ApplicationPartitionToEcuPartitionMapping, AsynchronousServerCallResult Point, AtpBlueprint, AtpBlueprintable, AtpClassifier, AtpFeature, AutosarOperationArgumentInstance, AutosarVariableInstance, BinaryManifestAddressableObject, BinaryManifestItemDefinition, Binary ManifestResource, BinaryManifestResourceDefinition, BlockState, BswInternalTriggeringPoint, Bsw ModuleDependency, BuildActionEntity, BuildActionEnvironment, CanTpAddress, CanTpChannel, CanTp Node, Chapter, ClassContentConditional, ClientIdDefinition, ClientServerOperation, Code, Collectable Element, ComManagementMapping, CommConnectorPort, CommunicationConnector, Communication Controller, Compiler, ConsistencyNeeds, ConsumedEventGroup, CouplingPort, CouplingPortStructural Element, CpSoftwareClusterResource, CpSoftwareClusterResourceToApplicationPartitionMapping, Cp SoftwareClusterToEcuInstanceMapping, CpSoftwareClusterToResourceMapping, CryptoService Mapping, DataPrototypeGroup, DataTransformation, DependencyOnArtifact, DiagEventDebounce Algorithm, DiagnosticConnectedIndicator, DiagnosticDataElement, DiagnosticFunctionInhibitSource, DiagnosticRoutineSubfunction, DltArgument, DltLogChannel, DltMessage, DolpInterface, DolpLogic Address, DolpRoutingActivation, ECUMapping, EOCExecutableEntityRefAbstract, EcuPartition, Ecuc ContainerValue, EcucDefinitionElement, EcucDestinationUriDef, EcucEnumerationLiteralDef, Ecuc Query, EcucValidationCondition, EndToEndProtection, EthernetWakeupSleepOnDataLineConfig, ExclusiveArea, ExecutableEntity, ExecutionTime, FMAttributeDef, FMFeatureMapAssertion, FMFeature MapCondition, FMFeatureMapElement, FMFeatureRelation, FMFeatureRestriction, FMFeatureSelection, FlatInstanceDescriptor, FlexrayArTpNode, FlexrayTpConnectionControl, FlexrayTpNode, FlexrayTpPdu Pool, FrameTriggering, GeneralParameter, GlobalTimeGateway, GlobalTimeMaster, GlobalTimeSlave,</i>





Class	<i>Identifiable</i> (abstract)			
	△ <i>HeapUsage</i> , <i>HwAttributeDef</i> , <i>HwAttributeLiteralDef</i> , <i>HwPin</i> , <i>HwPinGroup</i> , <i>IPSecRule</i> , <i>IPv6ExtHeaderFilterList</i> , <i>ISignalToIPduMapping</i> , <i>ISignalTriggering</i> , <i>IdentCaption</i> , <i>InternalTriggeringPoint</i> , <i>J1939SharedAddressCluster</i> , <i>J1939TpNode</i> , <i>Keyword</i> , <i>LifeCycleState</i> , <i>LinScheduleTable</i> , <i>LinTpNode</i> , <i>Linker</i> , <i>MacMulticastGroup</i> , <i>McDataInstance</i> , <i>MemorySection</i> , <i>ModeDeclaration</i> , <i>ModeDeclarationMapping</i> , <i>ModeSwitchPoint</i> , <i>NetworkEndpoint</i> , <i>NmCluster</i> , <i>NmEcu</i> , <i>NmNode</i> , <i>NvBlockDescriptor</i> , <i>PackageableElement</i> , <i>ParameterAccess</i> , <i>PduToFrameMapping</i> , <i>PduTriggering</i> , <i>PerInstanceMemory</i> , <i>PhysicalChannel</i> , <i>PortElementToCommunicationResourceMapping</i> , <i>PortGroup</i> , <i>PortInterfaceMapping</i> , <i>PossibleErrorReaction</i> , <i>ResourceConsumption</i> , <i>RootSwCompositionPrototype</i> , <i>RptComponent</i> , <i>RptContainer</i> , <i>RptExecutableEntity</i> , <i>RptExecutableEntityEvent</i> , <i>RptExecutionContext</i> , <i>RptProfile</i> , <i>RptServicePoint</i> , <i>RunnableEntityGroup</i> , <i>SdgAttribute</i> , <i>SdgClass</i> , <i>SecureCommunicationAuthenticationProps</i> , <i>SecureCommunicationFreshnessProps</i> , <i>SecurityEventContextProps</i> , <i>ServerCallPoint</i> , <i>ServiceNeeds</i> , <i>SignalServiceTranslationElementProps</i> , <i>SignalServiceTranslationEventProps</i> , <i>SignalServiceTranslationProps</i> , <i>SocketAddress</i> , <i>SomeipTpChannel</i> , <i>SpecElementReference</i> , <i>StackUsage</i> , <i>StaticSocketConnection</i> , <i>StructuredReq</i> , <i>SwGenericAxisParamType</i> , <i>SwServiceArg</i> , <i>SwcServiceDependency</i> , <i>SwcToApplicationPartitionMapping</i> , <i>SwcToEcuMapping</i> , <i>SwcToImplMapping</i> , <i>SystemMapping</i> , <i>TDCpSoftwareClusterMapping</i> , <i>TDCpSoftwareClusterResourceMapping</i> , <i>TcpOptionFilterList</i> , <i>TimingCondition</i> , <i>TimingConstraint</i> , <i>TimingDescription</i> , <i>TimingExtensionResource</i> , <i>TimingModelInstance</i> , <i>TlsCryptoCipherSuite</i> , <i>Topic1</i> , <i>TpAddress</i> , <i>TraceableTable</i> , <i>TraceableText</i> , <i>TracedFailure</i> , <i>TransformationProps</i> , <i>TransformationTechnology</i> , <i>Trigger</i> , <i>VariableAccess</i> , <i>VariationPointProxy</i> , <i>ViewMap</i> , <i>VlanConfig</i> , <i>WaitPoint</i>			
Attribute	Type	Mult.	Kind	Note
adminData	AdminData	0..1	aggr	This represents the administrative data for the identifiable object. <b>Tags:</b> xml.sequenceOffset=-40
annotation	Annotation	*	aggr	Possibility to provide additional notes while defining a model element (e.g. the ECU Configuration Parameter Values). These are not intended as documentation but are mere design notes. <b>Tags:</b> xml.sequenceOffset=-25
category	CategoryString	0..1	attr	The category is a keyword that specializes the semantics of the Identifiable. It affects the expected existence of attributes and the applicability of constraints. <b>Tags:</b> xml.sequenceOffset=-50
desc	MultiLanguageOverviewParagraph	0..1	aggr	This represents a general but brief (one paragraph) description what the object in question is about. It is only one paragraph! Desc is intended to be collected into overview tables. This property helps a human reader to identify the object in question.  More elaborate documentation, (in particular how the object is built or used) should go to "introduction". <b>Tags:</b> xml.sequenceOffset=-60
introduction	DocumentationBlock	0..1	aggr	This represents more information about how the object in question is built or is used. Therefore it is a DocumentationBlock. <b>Tags:</b> xml.sequenceOffset=-30
uuid	String	0..1	attr	The purpose of this attribute is to provide a globally unique identifier for an instance of a meta-class. The values of this attribute should be globally unique strings prefixed by the type of identifier. For example, to include a DCE UUID as defined by The Open Group, the UUID would be preceded by "DCE:". The values of this attribute may be used to support merging of different AUTOSAR models. The form of the UUID (Universally Unique Identifier) is taken from a standard defined by the Open Group (was Open Software Foundation). This standard is







Class	Identifiable (abstract)			
				<p style="text-align: center;">△</p> widely used, including by Microsoft for COM (GUIDs) and by many companies for DCE, which is based on CORBA. The method for generating these 128-bit IDs is published in the standard and the effectiveness and uniqueness of the IDs is not in practice disputed. If the id namespace is omitted, DCE is assumed. An example is "DCE:2fac1234-31f8-11b4-a222-08002b34c003". The uuid attribute has no semantic meaning for an AUTOSAR model and there is no requirement for AUTOSAR tools to manage the timestamp. <b>Tags:</b> xml.attribute=true

**Table A.17: Identifiable**

Class	Implementation (abstract)			
<b>Package</b>	M2::AUTOSARTemplates::CommonStructure::Implementation			
<b>Note</b>	Description of an implementation a single software component or module.			
<b>Base</b>	ARElement, ARObject, CollectableElement, Identifiable, MultilanguageReferrable, PackageableElement, Referrable			
<b>Subclasses</b>	BswImplementation, SwcImplementation			
Attribute	Type	Mult.	Kind	Note
buildActionManifest	BuildActionManifest	0..1	ref	A manifest specifying the intended build actions for the software delivered with this implementation. <b>Stereotypes:</b> atpVariation <b>Tags:</b> vh.latestBindingTime=codeGenerationTime
codeDescriptor	Code	*	aggr	Specifies the provided implementation code.
compiler	Compiler	*	aggr	Specifies the compiler for which this implementation has been released
generatedArtifact	DependencyOnArtifact	*	aggr	Relates to an artifact that will be generated during the integration of this Implementation by an associated generator tool. Note that this is an optional information since it might not always be in the scope of a single module or component to provide this information. <b>Stereotypes:</b> atpVariation <b>Tags:</b> vh.latestBindingTime=preCompileTime
hwElement	HwElement	*	ref	The hardware elements (e.g. the processor) required for this implementation.
linker	Linker	*	aggr	Specifies the linker for which this implementation has been released.
mcSupport	McSupportData	0..1	aggr	The measurement & calibration support data belonging to this implementation. The aggregation is <<atpSplitable>> because in case of an already existing BSW Implementation model, this description will be added later in the process, namely at code generation time. <b>Stereotypes:</b> atpSplitable <b>Tags:</b> atp.Splitkey=mcSupport
programmingLanguage	ProgramminglanguageEnum	0..1	attr	Programming language the implementation was created in.





<b>Class</b>	<b>Implementation (abstract)</b>			
requiredArtifact	DependencyOnArtifact	*	aggr	Specifies that this Implementation depends on the existence of another artifact (e.g. a library). This aggregation of DependencyOnArtifact is subject to variability with the purpose to support variability in the implementations. Different algorithms in the implementation might cause different dependencies, e.g. the number of used libraries.  <b>Stereotypes:</b> atpVariation <b>Tags:</b> vh.latestBindingTime=preCompileTime
requiredGeneratorTool	DependencyOnArtifact	*	aggr	Relates this Implementation to a generator tool in order to generate additional artifacts during integration.  <b>Stereotypes:</b> atpVariation <b>Tags:</b> vh.latestBindingTime=preCompileTime
resourceConsumption	ResourceConsumption	0..1	aggr	All static and dynamic resources for each implementation are described within the ResourceConsumption class.  <b>Stereotypes:</b> atpSplittable <b>Tags:</b> atp.Splitkey=resourceConsumption.shortName
swcBswMapping	SwcBswMapping	0..1	ref	This allows a mapping between an SWC and a BSW behavior to be attached to an implementation description (for AUTOSAR Service, ECU Abstraction and Complex Driver Components). It is up to the methodology to define whether this reference has to be set for the Swc- or Bsw Implementation or for both.
swVersion	RevisionLabelString	0..1	attr	Software version of this implementation. The numbering contains three levels (like major, minor, patch), its values are vendor specific.
usedCodeGenerator	String	0..1	attr	Optional: code generator used.
vendorId	PositiveInteger	0..1	attr	Vendor ID of this Implementation according to the AUTOSAR vendor list

**Table A.18: Implementation**

<b>Class</b>	<b>ImplementationDataType</b>			
<b>Package</b>	M2::AUTOSARTemplates::CommonStructure::ImplementationDataTypes			
<b>Note</b>	Describes a reusable data type on the implementation level. This will typically correspond to a typedef in C-code.  <b>Tags:</b> atp.recommendedPackage=ImplementationDataTypes			
<b>Base</b>	<i>ARElement, ARObject, AbstractImplementationDataType, AtpBlueprint, AtpBlueprintable, AtpClassifier, AtpType, AutosarDataType, CollectableElement, Identifiable, MultilanguageReferrable, PackageableElement, Referrable</i>			
<b>Attribute</b>	<b>Type</b>	<b>Mult.</b>	<b>Kind</b>	<b>Note</b>
dynamicArraySizeProfile	String	0..1	attr	Specifies the profile which the array will follow in case this data type is a variable size array.
isStructWithOptionalElement	Boolean	0..1	attr	This attribute is only valid if the attribute category is set to STRUCTURE.  If set to True, this attribute indicates that the ImplementationDataType has been created with the intention to define at least one element of the structure as optional.





Class	ImplementationDataType			
subElement (ordered)	<a href="#">ImplementationDataTypeElement</a>	*	aggr	<p>Specifies an element of an array, struct, or union data type.</p> <p>The aggregation of ImplementationDataTypeElement is subject to variability with the purpose to support the conditional existence of elements inside a ImplementationDataType representing a structure.</p> <p><b>Stereotypes:</b> atpVariation  <b>Tags:</b>vh.latestBindingTime=preCompileTime</p>
symbolProps	SymbolProps	0..1	aggr	<p>This represents the SymbolProps for the ImplementationDataType.</p> <p><b>Stereotypes:</b> atpSplittable  <b>Tags:</b>atp.Splitkey=symbolProps.shortName</p>
typeEmitter	NameToken	0..1	attr	<p>This attribute is used to control which part of the AUTOSAR toolchain is supposed to trigger data type definitions.</p>

**Table A.19: ImplementationDataType**

Class	ImplementationDataTypeElement			
<b>Package</b>	M2::AUTOSARTemplates::CommonStructure::ImplementationDataTypes			
<b>Note</b>	<p>Declares a data object which is locally aggregated. Such an element can only be used within the scope where it is aggregated.</p> <p>This element either consists of further subElements or it is further defined via its swDataDefProps.</p> <p>There are several use cases within the system of ImplementationDataTypes for such a local declaration:</p> <ul style="list-style-type: none"> <li>• It can represent the elements of an array, defining the element type and array size</li> <li>• It can represent an element of a struct, defining its type</li> <li>• It can be the local declaration of a debug element.</li> </ul>			
<b>Base</b>	<i>ARObject, AbstractImplementationDataTypeElement, AtpClassifier, AtpFeature, AtpStructureElement, Identifiable, MultilanguageReferrable, Referrable</i>			
Attribute	Type	Mult.	Kind	Note
arrayImplPolicy	ArrayImplPolicyEnum	0..1	attr	This attribute controls the implementation of the payload of an array. It shall only be used if the enclosing ImplementationDataType constitutes an array.
arraySize	PositiveInteger	0..1	attr	<p>The existence of this attributes (if bigger than 0) defines the size of an array and declares that this ImplementationDataTypeElement represents the type of each single array element.</p> <p><b>Stereotypes:</b> atpVariation  <b>Tags:</b>vh.latestBindingTime=preCompileTime</p>
arraySizeHandling	ArraySizeHandlingEnum	0..1	attr	The way how the size of the array is handled in case of a variable size array.
arraySizeSemantics	<a href="#">ArraySizeSemanticsEnum</a>	0..1	attr	This attribute controls the meaning of the value of the array size.
isOptional	Boolean	0..1	attr	This attribute represents the ability to declare the enclosing ImplementationDataTypeElement as optional. This means that, at runtime, the ImplementationDataTypeElement may or may not have a valid value and shall therefore be ignored.





Class	ImplementationDataTypeElement			
				The underlying runtime software provides means to set the CppImplementationDataTypeElement as not valid at the sending end of a communication and determine its validity at the receiving end.
subElement (ordered)	ImplementationDataTypeElement	*	aggr	Element of an array, struct, or union in case of a nested declaration (i.e. without using "typedefs").  The aggregation of ImplementationDataTypeElement is subject to variability with the purpose to support the conditional existence of elements inside a ImplementationDataType representing a structure.  <b>Stereotypes:</b> atpVariation <b>Tags:</b> vh.latestBindingTime=preCompileTime
swDataDef Props	SwDataDefProps	0..1	aggr	The properties of this ImplementationDataTypeElement.

**Table A.20: ImplementationDataTypeElement**

Class	InternalBehavior (abstract)			
Package	M2::AUTOSARTemplates::CommonStructure::InternalBehavior			
Note	Common base class (abstract) for the internal behavior of both software components and basic software modules/clusters.			
Base	ARObject, AtpClassifier, AtpFeature, AtpStructureElement, Identifiable, MultilanguageReferrable, Referrable			
Subclasses	BswInternalBehavior, SwcInternalBehavior			
Attribute	Type	Mult.	Kind	Note
constantMemory	ParameterDataPrototype	*	aggr	Describes a read only memory object containing characteristic value(s) implemented by this InternalBehavior.  The shortName of ParameterDataPrototype has to be equal to the 'C' identifier of the described constant.  The characteristic value(s) might be shared between SwComponentPrototypes of the same SwComponentType.  The aggregation of constantMemory is subject to variability with the purpose to support variability in the software component or module implementations. Typically different algorithms in the implementation are requiring different number of memory objects.  <b>Stereotypes:</b> atpSplitable; atpVariation <b>Tags:</b> atp.Splitkey=constantMemory.shortName, constantMemory.variationPoint.shortLabel vh.latestBindingTime=preCompileTime
constantValueMapping	ConstantSpecificationMappingSet	*	ref	Reference to the ConstantSpecificationMapping to be applied for the particular InternalBehavior  <b>Stereotypes:</b> atpSplitable <b>Tags:</b> atp.Splitkey=constantValueMapping
dataTypeMapping	DataTypeMappingSet	*	ref	Reference to the DataTypeMapping to be applied for the particular InternalBehavior  <b>Stereotypes:</b> atpSplitable <b>Tags:</b> atp.Splitkey=dataTypeMapping





<b>Class</b>	<b>InternalBehavior</b> (abstract)			
exclusiveArea	ExclusiveArea	*	aggr	<p>This specifies an ExclusiveArea for this InternalBehavior. The exclusiveArea is local to the component resp. module. The aggregation of ExclusiveAreas is subject to variability. Note: the number of ExclusiveAreas might vary due to the conditional existence of RunnableEntities or BswModuleEntities.</p> <p><b>Stereotypes:</b> atpSplitable; atpVariation <b>Tags:</b> atp.Splitkey=exclusiveArea.shortName, exclusiveArea.variationPoint.shortLabel vh.latestBindingTime=preCompileTime</p>
exclusiveAreaNestingOrder	ExclusiveAreaNestingOrder	*	aggr	<p>This represents the set of ExclusiveAreaNestingOrder owned by the InternalBehavior.</p> <p><b>Stereotypes:</b> atpSplitable; atpVariation <b>Tags:</b> atp.Splitkey=exclusiveAreaNestingOrder.shortName, exclusiveAreaNestingOrder.variationPoint.shortLabel vh.latestBindingTime=preCompileTime</p>
staticMemory	VariableDataPrototype	*	aggr	<p>Describes a read and writeable static memory object representing measurement variables implemented by this software component. The term "static" is used in the meaning of "non-temporary" and does not necessarily specify a linker encapsulation. This kind of memory is only supported if supportsMultipleInstantiation is FALSE.</p> <p>The shortName of the VariableDataPrototype has to be equal with the "C" identifier of the described variable.</p> <p>The aggregation of staticMemory is subject to variability with the purpose to support variability in the software component's implementations.</p> <p>Typically different algorithms in the implementation are requiring different number of memory objects.</p> <p><b>Stereotypes:</b> atpSplitable; atpVariation <b>Tags:</b> atp.Splitkey=staticMemory.shortName, staticMemory.variationPoint.shortLabel vh.latestBindingTime=preCompileTime</p>

**Table A.21: InternalBehavior**

<b>Class</b>	<b>PortAPIOption</b>			
<b>Package</b>	M2::AUTOSARTemplates::SWComponentTemplate::SwcInternalBehavior::PortAPIOptions			
<b>Note</b>	Options how to generate the signatures of calls for an AtomicSwComponentType in order to communicate over a PortPrototype (for calls into a RunnableEntity as well as for calls from a RunnableEntity to the PortPrototype).			
<b>Base</b>	ARObject			
<b>Attribute</b>	<b>Type</b>	<b>Mult.</b>	<b>Kind</b>	<b>Note</b>
enableTakeAddress	Boolean	0..1	attr	If set to true, the software-component is able to use the API reference for deriving a pointer to an object.
errorHandling	<a href="#">DataTransformationErrorHandlingEnum</a>	0..1	attr	This specifies whether a RunnableEntity accessing a Port Prototype that is referenced by this PortAPIOption shall specifically handle transformer errors or not.





Class	PortAPIOption			
indirectAPI	Boolean	0..1	attr	If set to true this attribute specifies an "indirect API" to be generated for the associated port which means that the software-component is able to access the actions on a port via a pointer to an object representing a port. This allows e.g. iterating over ports in a loop. This option has no effect for PPortPrototypes of client/server interfaces.
port	PortPrototype	0..1	ref	The option is valid for generated functions related to communication over this port
portArgValue (ordered)	<a href="#">PortDefinedArgument Value</a>	*	aggr	An argument value defined by this port.
supported Feature	SwcSupportedFeature	*	aggr	This collection specifies which features are supported by the RunnableEntitys which access a PortPrototype that it referenced by this PortAPIOption.
transformer Status Forwarding	DataTransformation StatusForwardingEnum	0..1	attr	This specifies whether a RunnableEntity accessing a Port Prototype that is referenced by this PortAPIOption shall be able to forward a status to the transformer chain.

**Table A.22: PortAPIOption**

Class	PortDefinedArgumentValue			
<b>Package</b>	M2::AUTOSARTemplates::SWComponentTemplate::SwcInternalBehavior::PortAPIOptions			
<b>Note</b>	A PortDefinedArgumentValue is passed to a RunnableEntity dealing with the ClientServerOperations provided by a given PortPrototype. Note that this is restricted to PPortPrototypes of a ClientServer Interface.			
<b>Base</b>	ARObject			
Attribute	Type	Mult.	Kind	Note
value	ValueSpecification	0..1	aggr	Specifies the actual value.
valueType	<a href="#">ImplementationData Type</a>	0..1	tref	The implementation type of this argument value. It should not be composite type or a pointer. <b>Stereotypes:</b> isOfType

**Table A.23: PortDefinedArgumentValue**

Class	SOMEIPTransformationProps			
<b>Package</b>	M2::AUTOSARTemplates::SystemTemplate::Transformer			
<b>Note</b>	The class SOMEIPTransformationProps specifies SOME/IP specific configuration properties.			
<b>Base</b>	ARObject, <a href="#">Identifiable</a> , <a href="#">MultilanguageReferrable</a> , <a href="#">Referrable</a> , <a href="#">TransformationProps</a>			
Attribute	Type	Mult.	Kind	Note
alignment	PositiveInteger	0..1	attr	Defines the padding for alignment purposes that will be added by the SOME/IP transformer after the serialized data of the variable data length data element. The alignment shall be specified in Bits.
sizeOfArray LengthField	PositiveInteger	0..1	attr	This attribute describes the size of the length field (in Bytes) that will be put in front of the referenced Array in the SOME/IP message.
sizeOfString LengthField	PositiveInteger	0..1	attr	This attribute describes the size of the length field (in Bytes) that will be put in front of the referenced String in the SOME/IP message.





<b>Class</b>	<b>SOMEIPTransformationProps</b>			
sizeOfStruct LengthField	PositiveInteger	0..1	attr	This attribute describes the size of the length field (in Bytes) that will be put in front of a Structure in the SOME/IP message.
sizeOfUnion LengthField	PositiveInteger	0..1	attr	This attribute describes the size of the length field (in Bytes) that will be put in front of a Union in the SOME/IP message.

**Table A.24: SOMEIPTransformationProps**

<b>Enumeration</b>	<b>SOMEIPTransformerSessionHandlingEnum</b>
<b>Package</b>	M2::AUTOSARTemplates::SystemTemplate::Transformer
<b>Note</b>	Enables or disable session handling for SOME/IP transformer
<b>Literal</b>	<b>Description</b>
sessionHandling Active	The SOME/IP Transformer shall use session handling <b>Tags:</b> atp.EnumerationLiteralIndex=0
sessionHandling Inactive	The SOME/IP Transformer doesn't use session handling <b>Tags:</b> atp.EnumerationLiteralIndex=1

**Table A.25: SOMEIPTransformerSessionHandlingEnum**

<b>Class</b>	<b>SenderReceiverInterface</b>			
<b>Package</b>	M2::AUTOSARTemplates::SWComponentTemplate::PortInterface			
<b>Note</b>	A sender/receiver interface declares a number of data elements to be sent and received. <b>Tags:</b> atp.recommendedPackage=PortInterfaces			
<b>Base</b>	ARElement, ARObject, AtpBlueprint, AtpBlueprintable, AtpClassifier, AtpType, CollectableElement, DataInterface, Identifiable, MultilanguageReferrable, PackageableElement, PortInterface, Referrable			
<b>Attribute</b>	<b>Type</b>	<b>Mult.</b>	<b>Kind</b>	<b>Note</b>
dataElement	VariableDataPrototype	*	aggr	The data elements of this SenderReceiverInterface.
invalidation Policy	InvalidationPolicy	*	aggr	InvalidationPolicy for a particular dataElement
metaDataItem Set	MetaDataTypeSet	*	aggr	This aggregation defines fixed sets of meta-data items associated with dataElements of the enclosing Sender ReceiverInterface

**Table A.26: SenderReceiverInterface**

<b>Class</b>	<b>SenderReceiverToSignalMapping</b>			
<b>Package</b>	M2::AUTOSARTemplates::SystemTemplate::DataMapping			
<b>Note</b>	Mapping of a sender receiver communication data element to a signal.			
<b>Base</b>	ARObject, DataMapping			
<b>Attribute</b>	<b>Type</b>	<b>Mult.</b>	<b>Kind</b>	<b>Note</b>
dataElement	VariableDataPrototype	1	iref	Reference to the data element. <b>InstanceRef implemented by:</b> VariableDataPrototypeIn SystemInstanceRef





Class	SenderReceiverToSignalMapping			
senderToSignal TextTable Mapping	TextTableMapping	0..1	aggr	This mapping allows for the text-table translation between the sending DataPrototype that is defined in the Port Prototype and the physicalProps defined for the System Signal.
signalTo ReceiverText TableMapping	TextTableMapping	0..1	aggr	This mapping allows for the text-table translation between the physicalProps defined for the SystemSignal and a receiving DataPrototype that is defined in the Port Prototype.
systemSignal	<a href="#">SystemSignal</a>	1	ref	Reference to the system signal used to carry the data element.

**Table A.27: SenderReceiverToSignalMapping**

Class	SwBaseType			
Package	M2::MSR::AsamHdo::BaseTypes			
Note	This meta-class represents a base type used within ECU software. <b>Tags:</b> atp.recommendedPackage=BaseTypes			
Base	<a href="#">ARElement</a> , <a href="#">ARObject</a> , <a href="#">AtpBlueprint</a> , <a href="#">AtpBlueprintable</a> , <a href="#">BaseType</a> , <a href="#">CollectableElement</a> , <a href="#">Identifiable</a> , <a href="#">MultilanguageReferrable</a> , <a href="#">PackageableElement</a> , <a href="#">Referrable</a>			
Attribute	Type	Mult.	Kind	Note
–	–	–	–	–

**Table A.28: SwBaseType**

Class	<<atpVariation>> SwDataDefProps			
Package	M2::MSR::DataDictionary::DataDefProperties			
Note	This class is a collection of properties relevant for data objects under various aspects. One could consider this class as a "pattern of inheritance by aggregation". The properties can be applied to all objects of all classes in which SwDataDefProps is aggregated.  Note that not all of the attributes or associated elements are useful all of the time. Hence, the process definition (e.g. expressed with an OCL or a Document Control Instance MSR-DCI) has the task of implementing limitations.  SwDataDefProps covers various aspects: <ul style="list-style-type: none"> <li>• Structure of the data element for calibration use cases: is it a single value, a curve, or a map, but also the recordLayouts which specify how such elements are mapped/converted to the Data Types in the programming language (or in AUTOSAR). This is mainly expressed by properties like swRecordLayout and swCalprmAxisSet</li> <li>• Implementation aspects, mainly expressed by swImplPolicy, swVariableAccessImplPolicy, swAddrMethod, swPointerTargetProps, baseType, implementationDataType and additionalNativeTypeQualifier</li> <li>• Access policy for the MCD system, mainly expressed by swCalibrationAccess</li> <li>• Semantics of the data element, mainly expressed by compuMethod and/or unit, dataConstr, invalidValue</li> <li>• Code generation policy provided by swRecordLayout</li> </ul> <b>Tags:</b> vh.latestBindingTime=codeGenerationTime			
Base	<a href="#">ARObject</a>			
Attribute	Type	Mult.	Kind	Note
–	–	–	–	–







Class	<<atpVariation>> SwDataDefProps			
additionalNativeTypeQualifier	NativeDeclarationString	0..1	attr	This attribute is used to declare native qualifiers of the programming language which can neither be deduced from the baseType (e.g. because the data object describes a pointer) nor from other more abstract attributes. Examples are qualifiers like "volatile", "strict" or "enum" of the C-language. All such declarations have to be put into one string. <b>Tags:</b> xml.sequenceOffset=235
annotation	Annotation	*	aggr	This aggregation allows to add annotations (yellow pads ...) related to the current data object. <b>Tags:</b> xml.roleElement=true xml.roleWrapperElement=true xml.sequenceOffset=20 xml.typeElement=false xml.typeWrapperElement=false
baseType	<a href="#">SwBaseType</a>	0..1	ref	Base type associated with the containing data object. <b>Tags:</b> xml.sequenceOffset=50
compuMethod	CompuMethod	0..1	ref	Computation method associated with the semantics of this data object. <b>Tags:</b> xml.sequenceOffset=180
dataConstr	DataConstr	0..1	ref	Data constraint for this data object. <b>Tags:</b> xml.sequenceOffset=190
displayFormat	DisplayFormatString	0..1	attr	This property describes how a number is to be rendered e.g. in documents or in a measurement and calibration system. <b>Tags:</b> xml.sequenceOffset=210
displayPresentation	DisplayPresentationEnum	0..1	attr	This attribute controls the presentation of the related data for measurement and calibration tools.
implementationDataType	AbstractImplementationDataType	0..1	ref	This association denotes the ImplementationDataType of a data declaration via its aggregated SwDataDefProps. It is used whenever a data declaration is not directly referring to a base type. Especially <ul style="list-style-type: none"> <li>• redefinition of an ImplementationDataType via a "typedef" to another ImplementationDatatype</li> <li>• the target type of a pointer (see SwPointerTarget Props), if it does not refer to a base type directly</li> <li>• the data type of an array or record element within an ImplementationDataType, if it does not refer to a base type directly</li> <li>• the data type of an SwServiceArg, if it does not refer to a base type directly</li> </ul> <b>Tags:</b> xml.sequenceOffset=215
invalidValue	ValueSpecification	0..1	aggr	Optional value to express invalidity of the actual data element. <b>Tags:</b> xml.sequenceOffset=255
stepSize	Float	0..1	attr	This attribute can be used to define a value which is added to or subtracted from the value of a DataPrototype when using up/down keys while calibrating.





Class	<<atpVariation>> SwDataDefProps			
swAddrMethod	SwAddrMethod	0..1	ref	<p>Addressing method related to this data object. Via an association to the same SwAddrMethod it can be specified that several DataPrototypes shall be located in the same memory without already specifying the memory section itself.</p> <p><b>Tags:</b>xml.sequenceOffset=30</p>
swAlignment	AlignmentType	0..1	attr	<p>The attribute describes the intended alignment of the DataPrototype. If the attribute is not defined the alignment is determined by the swBaseType size and the memory AllocationKeywordPolicy of the referenced SwAddr Method.</p> <p><b>Tags:</b>xml.sequenceOffset=33</p>
swBit Representation	SwBitRepresentation	0..1	aggr	<p>Description of the binary representation in case of a bit variable.</p> <p><b>Tags:</b>xml.sequenceOffset=60</p>
swCalibration Access	SwCalibrationAccess Enum	0..1	attr	<p>Specifies the read or write access by MCD tools for this data object.</p> <p><b>Tags:</b>xml.sequenceOffset=70</p>
swCalprmAxis Set	SwCalprmAxisSet	0..1	aggr	<p>This specifies the properties of the axes in case of a curve or map etc. This is mainly applicable to calibration parameters.</p> <p><b>Tags:</b>xml.sequenceOffset=90</p>
swComparison Variable	SwVariableRefProxy	*	aggr	<p>Variables used for comparison in an MCD process.</p> <p><b>Tags:</b> xml.sequenceOffset=170 xml.typeElement=false</p>
swData Dependency	SwDataDependency	0..1	aggr	<p>Describes how the value of the data object has to be calculated from the value of another data object (by the MCD system).</p> <p><b>Tags:</b>xml.sequenceOffset=200</p>
swHostVariable	SwVariableRefProxy	0..1	aggr	<p>Contains a reference to a variable which serves as a host-variable for a bit variable. Only applicable to bit objects.</p> <p><b>Tags:</b> xml.sequenceOffset=220 xml.typeElement=false</p>
swImplPolicy	SwImplPolicyEnum	0..1	attr	<p>Implementation policy for this data object.</p> <p><b>Tags:</b>xml.sequenceOffset=230</p>
swIntended Resolution	Numerical	0..1	attr	<p>The purpose of this element is to describe the requested quantization of data objects early on in the design process.</p> <p>The resolution ultimately occurs via the conversion formula present (compuMethod), which specifies the transition from the physical world to the standardized world (and vice-versa) (here, "the slope per bit" is present implicitly in the conversion formula).</p> <p>In the case of a development phase without a fixed conversion formula, a pre-specification can occur through swIntendedResolution.</p> <p>The resolution is specified in the physical domain according to the property "unit".</p> <p><b>Tags:</b>xml.sequenceOffset=240</p>





Class	<<atpVariation>> SwDataDefProps			
swInterpolationMethod	Identifier	0..1	attr	This is a keyword identifying the mathematical method to be applied for interpolation. The keyword needs to be related to the interpolation routine which needs to be invoked. <b>Tags:</b> xml.sequenceOffset=250
swIsVirtual	Boolean	0..1	attr	This element distinguishes virtual objects. Virtual objects do not appear in the memory, their derivation is much more dependent on other objects and hence they shall have a swDataDependency . <b>Tags:</b> xml.sequenceOffset=260
swPointerTargetProps	SwPointerTargetProps	0..1	aggr	Specifies that the containing data object is a pointer to another data object. <b>Tags:</b> xml.sequenceOffset=280
swRecordLayout	SwRecordLayout	0..1	ref	Record layout for this data object. <b>Tags:</b> xml.sequenceOffset=290
swRefreshTiming	MultidimensionalTime	0..1	aggr	This element specifies the frequency in which the object involved shall be or is called or calculated. This timing can be collected from the task in which write access processes to the variable run. But this cannot be done by the MCD system.  So this attribute can be used in an early phase to express the desired refresh timing and later on to specify the real refresh timing. <b>Tags:</b> xml.sequenceOffset=300
swTextProps	<a href="#">SwTextProps</a>	0..1	aggr	the specific properties if the data object is a text object. <b>Tags:</b> xml.sequenceOffset=120
swValueBlockSize	Numerical	0..1	attr	This represents the size of a Value Block <b>Stereotypes:</b> atpVariation <b>Tags:</b> vh.latestBindingTime=preCompileTime xml.sequenceOffset=80
swValueBlockSizeMult (ordered)	Numerical	*	attr	This attribute is used to specify the dimensions of a value block (VAL_BLK) for the case that that value block has more than one dimension.  The dimensions given in this attribute are ordered such that the first entry represents the first dimension, the second entry represents the second dimension, and so on.  For one-dimensional value blocks the attribute swValueBlockSize shall be used and this attribute shall not exist. <b>Stereotypes:</b> atpVariation <b>Tags:</b> vh.latestBindingTime=preCompileTime
unit	Unit	0..1	ref	Physical unit associated with the semantics of this data object. This attribute applies if no compuMethod is specified. If both units (this as well as via compuMethod) are specified the units shall be compatible. <b>Tags:</b> xml.sequenceOffset=350





<b>Class</b>	<<atpVariation>> <b>SwDataDefProps</b>			
valueAxisDataType	<a href="#">ApplicationPrimitiveDataType</a>	0..1	ref	The referenced ApplicationPrimitiveDataType represents the primitive data type of the value axis within a compound primitive (e.g. curve, map). It supersedes CompuMethod, Unit, and BaseType. <b>Tags:</b> xml.sequenceOffset=355

**Table A.29: SwDataDefProps**

<b>Class</b>	<b>SwTextProps</b>			
<b>Package</b>	M2::MSR::DataDictionary::DataDefProperties			
<b>Note</b>	This meta-class expresses particular properties applicable to strings in variables or calibration parameters.			
<b>Base</b>	ARObject			
<b>Attribute</b>	<b>Type</b>	<b>Mult.</b>	<b>Kind</b>	<b>Note</b>
arraySizeSemantics	<a href="#">ArraySizeSemanticsEnum</a>	0..1	attr	This attribute controls the semantics of the arraysize for the array representing the string in an ImplementationDataType.  It is there to support a safe conversion between ApplicationDatatype and ImplementationDatatype, even for variable length strings as required e.g. for Support of SAE J1939.
baseType	<a href="#">SwBaseType</a>	0..1	ref	This is the base type of one character in the string. In particular this baseType denotes the intended encoding of the characters in the string on level of ApplicationDataType. <b>Tags:</b> xml.sequenceOffset=30
swFillCharacter	Integer	0..1	attr	Filler character for text parameter to pad up to the maximum length swMaxTextSize.  The value will be interpreted according to the encoding specified in the associated base type of the data object, e.g. 0x30 (hex) represents the ASCII character zero as filler character and 0 (dec) represents an end of string as filler character.  The usage of the fill character depends on the arraySizeSemantics. <b>Tags:</b> xml.sequenceOffset=40
swMaxTextSize	Integer	0..1	attr	Specifies the maximum text size in characters. Note the size in bytes depends on the encoding in the corresponding baseType.  <b>Stereotypes:</b> atpVariation <b>Tags:</b> vh.latestBindingTime=preCompileTime xml.sequenceOffset=20

**Table A.30: SwTextProps**

<b>Class</b>	<b>SystemSignal</b>			
<b>Package</b>	M2::AUTOSARTemplates::SystemTemplate::Fibex::FibexCore::CoreCommunication			
<b>Note</b>	The system signal represents the communication system's view of data exchanged between SW components which reside on different ECUs. The system signals allow to represent this communication in a flattened structure, with exactly one system signal defined for each data element prototype sent and received by connected SW component instances. <b>Tags:</b> atp.recommendedPackage=SystemSignals			
<b>Base</b>	ARElement, ARObject, CollectableElement, Identifiable, MultilanguageReferrable, PackageableElement, Referrable			
<b>Attribute</b>	<b>Type</b>	<b>Mult.</b>	<b>Kind</b>	<b>Note</b>
dynamicLength	Boolean	1	attr	The length of dynamic length signals is variable in run-time. Only a maximum length of such a signal is specified in the configuration (attribute length in ISignal element).
physicalProps	SwDataDefProps	0..1	aggr	Specification of the physical representation.

**Table A.31: SystemSignal**

<b>Class</b>	<<atpVariation>> TransformationISignalProps (abstract)			
<b>Package</b>	M2::AUTOSARTemplates::SystemTemplate::Transformer			
<b>Note</b>	TransformationISignalProps holds all the attributes for the different TransformationTechnologies that are ISignal specific. <b>Tags:</b> vh.latestBindingTime=postBuild			
<b>Base</b>	ARObject, Describable			
<b>Subclasses</b>	EndToEndTransformationISignalProps, SOMEIPTransformationISignalProps, UserDefinedTransformationISignalProps			
<b>Attribute</b>	<b>Type</b>	<b>Mult.</b>	<b>Kind</b>	<b>Note</b>
csErrorReaction	CSTransformerErrorReactionEnum	0..1	attr	Defines whether the transformer chain of client/server communication coordinates an autonomous error reaction together with the RTE or whether any error reaction is the responsibility of the application.
dataPrototypeTransformationProps	DataPrototypeTransformationProps	*	aggr	Fine granular modeling of TransformationProps on the level of DataPrototypes.
transformer	TransformationTechnology	1	ref	Reference to the TransformationTechnology description that contains transformer specific and ISignal independent configuration properties.

**Table A.32: TransformationISignalProps**

<b>Class</b>	<b>TransformationTechnology</b>			
<b>Package</b>	M2::AUTOSARTemplates::SystemTemplate::Transformer			
<b>Note</b>	A TransformationTechnology is a transformer inside a transformer chain. <b>Tags:</b> xml.namePlural=TRANSFORMATION-TECHNOLOGIES			
<b>Base</b>	ARObject, Identifiable, MultilanguageReferrable, Referrable			
<b>Attribute</b>	<b>Type</b>	<b>Mult.</b>	<b>Kind</b>	<b>Note</b>
bufferProperties	BufferProperties	1	aggr	Aggregation of the mandatory BufferProperties.
hasInternalState	Boolean	0..1	attr	This attribute defines whether the Transformer has an internal state or not.





Class	TransformationTechnology			
needsOriginalData	Boolean	0..1	attr	Specifies whether this transformer gets access to the SWC's original data.
protocol	String	1	attr	Specifies the protocol that is implemented by this transformer.
transformationDescription	TransformationDescription	0..1	aggr	A transformer can be configured with transformer specific parameters which are represented by the TransformerDescription.  <b>Stereotypes:</b> atpVariation <b>Tags:</b> vh.latestBindingTime=postBuild
transformerClass	TransformerClassEnum	1	attr	Specifies to which transformer class this transformer belongs.
version	String	1	attr	Version of the implemented protocol.

**Table A.33: TransformationTechnology**

Class	TriggerToSignalMapping			
Package	M2::AUTOSARTemplates::SystemTemplate::DataMapping			
Note	This meta-class represents the ability to map a trigger to a SystemSignal of size 0. The Trigger does not transport any other information than its existence, therefore the limitation in terms of signal length.			
Base	ARObject, DataMapping			
Attribute	Type	Mult.	Kind	Note
systemSignal	SystemSignal	1	ref	This is the SystemSignal taken to transport the Trigger over the network.  <b>Tags:</b> xml.sequenceOffset=20
trigger	Trigger	1	iref	This represents the Trigger that shall be used to trigger RunnableEntities deployed to a remote ECU.  <b>Tags:</b> xml.sequenceOffset=10 <b>InstanceRef implemented by:</b> TriggerInSystemInstanceRef

**Table A.34: TriggerToSignalMapping**

## B Features of SOME/IP not supported by AUTOSAR SOME/IP transformer

The following features of SOME/IP are currently not supported by the SOME/IP transformer:

- Exceptions and exception-specific error data structures
- Tunneling of SOME/IP messages through CAN and Flexray leads to SOME/IP messages without parts of the header inserted by [4, SWS Socket Adaptor]
- Queued Fire&Forget methods without parameters are not supported by AUTOSAR at all. (Unqueued Fire&Forget methods without parameters and queued Fire&Forget methods with parameters are supported)

- The SOME/IP transformer doesn't check whether variable size arrays contain a minimal number of elements (reason: this is supported by SOME/IP protocol but not by AUTOSAR)

## C Examples

This appendix contains examples which are suitable to help understanding details of the SOME/IP Transformer.

### C.1 Serialization of a Client/Server Operation

As the serialization of inter-ECU Client/Server communication is the most complex scenario, this example will show the resulting APIs which exist in RTE and Transformer both on the Client and the Server as well an overview of the resulting serialized data on the network.

The example deals with two SWCs which are distributed to two ECUs which are connected over some kind of network. The SOME/IP Transformer shall be used to serialize the inter-ECU communication. The client calls a `ClientServerOperation` which is provided by the server. For the server, there are two `PortDefinedArgumentValues` defined which are applied to the runnable which implements the `ClientServerOperation`. These `PortDefinedArgumentValues` are only visible within the `InternalBehavior` of the server. They are not visible to the outside world (`ClientServerInterface`) - neither to the client nor in the data on the network.

The following tables define the example `ClientServerInterface` used here.

<b>Name</b>	SomeCSInterface	
<b>Comment</b>	A ClientServerInterface which contains anything needed to show serialization of ClientServerOperations by SOME/IP Transformer.	
<b>IsService</b>	false	
<b>Variation</b>	-	
<b>Possible Errors</b>	0	E_OK
	1	E_DATA_INCONSISTENT
	2	E_UNKNOWN_ERROR

**Table C.1: ClientServerInterface SomeCSInterface**

#### Operations

<b>Name</b>	SomeCSOperation
<b>Comments</b>	The ClientServerOperation which is used to demonstrate how the SOME/IP serialization for Client/Server communication works
<b>Variation</b>	-
<b>Parameters</b>	inputParam1

	Comment	A parameter which is handed over from the Client to the Server	
	Type	uint8	
	Variation	–	
	Direction	IN	
	inputParam2		
	Comment	A parameter which is handed over from the Client to the Server	
	Type	uint16	
	Variation	–	
	Direction	IN	
	biDirectionalParam		
	Comment	A parameter which is handed over from the Client to the Server, modified by the Server and handed back to the Client	
	Type	someStruct	
	Variation	–	
	Direction	INOUT	
	outputParam1		
	Comment	A parameter which is handed over from the Server to the Client	
	Type	uint16	
	Variation	–	
	Direction	OUT	
	outputParam2		
Comment	A parameter which is handed over from the Server to the Client		
Type	uint32		
Variation	–		
Direction	OUT		
<b>Possible Errors</b>	E_OK	Operation successful	
	E_DATA_INCONSISTENT	Data are inconsistent	
	E_UNKNOWN_ERROR	An unknown error occurred	

**Table C.2: Operation SomeCSOperation**

### C.1.1 Client

On the client side, the following RTE-API is generated according to [SWS\_Rte\_01102] based on the [ClientServerInterface](#) which is specified above and the attribute [errorHandling](#) of [PortAPIOption](#):

```
Std_ReturnType Rte_Call_ClientPort_SomeCSOperation
(
    uint8 inputParam1,
    uint16 inputParam2,
    someStruct *biDirectionalParam,
    uint16 *outputParam1,
    uint32 *outputParam2,
    Rte_TransformerError *transformerError)

```



For this signature the attribute `errorHandling` of `PortAPIOption` is set to `transformerErrorHandling`. If it would be set to `noTransformerErrorHandling`, the parameter `Rte_TransformerError *transformerError` would not be included in the signature above.

The signature above reflects an synchronous server call. For an asynchronous server call all OUT parameters would be missing for `Rte_Call` but an `Rte_Result` would be necessary instead. The examples for signatures and parameters shown here can be transferred analogously to `Rte_Result`.

This is the API used in the runnable of the client to call the remote server operation.

The RTE executes for the serialization of the request the SOME/IP Transformer with the following API which is specified in [[SWS\\_SomeIpXf\\_00141](#)]:

```
uint8 SomeIpXf_CSOpSerializer
    (const Rte-Cs_TransactionHandleType *TransactionHandle,
     uint8 *buffer,
     uint16 *bufferLength,
     uint8 inputParam1,
     uint16 inputParam2,
     someStruct biDirectionalParam)
```

This function will serialize the `TransactionHandle` and all IN/INOUT parameters for the request into the following format:

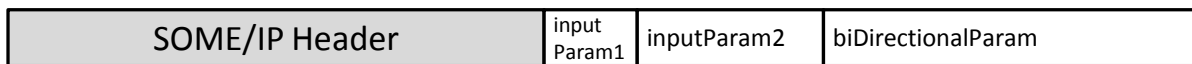

**Figure C.1: Example for serialized data of the Client/Server Request**

The SOME/IP Header contains the `TransactionHandle` (see [[SWS\\_SomeIpXf\\_00025](#)] and [[SWS\\_SomeIpXf\\_00026](#)]).

To deserialize the response that is received by the client after execution of the `ClientServerOperation` on the server the API (according to [[SWS\\_SomeIpXf\\_00145](#)]) is used:

```
uint8 SomeIpXf_Inv_CSOpSerializer
    (Rte-Cs_TransactionHandleType *TransactionHandle,
     const uint8 *buffer,
     uint16 bufferLength,
     Std_ReturnType *returnValue,
     someStruct *biDirectionalParam,
     uint16 *outputParam1,
     uint32 *outputParam2)
```

### C.1.2 Server

On the server side the [ClientServerOperation](#) is implemented by a runnable with the following signature which now contains the [PortDefinedArgumentValues](#) (see [\[SWS\\_Rte\\_01166\]](#)):

```
Std_ReturnType SomeCSOperation
    (uint8 portDefArg1,
     uint8 portDefArg2,
     uint8 inputParam1,
     uint16 inputParam2,
     someStruct *biDirectionalParam,
     uint16 *outputParam1,
     uint32 *outputParam2)
```

For the deserialization of the received request, the SOME/IP Transformer on the server side, provides according to [\[SWS\\_SomeIpXf\\_00141\]](#) this C-API:

```
uint8 SomeIpXf_Inv_CSOpSerializer
    (Rte-Cs_TransactionHandleType *TransactionHandle,
     const uint8 *buffer,
     uint16 bufferLength,
     uint8 *inputParam1,
     uint16 *inputParam2,
     someStruct *biDirectionalParam)
```

The function for serialization of the response is specified by [\[SWS\\_SomeIpXf\\_00145\]](#):

```
uint8 SomeIpXf_CSOpSerializer
    (const Rte-Cs_TransactionHandleType *TransactionHandle,
     uint8 *buffer,
     uint16 *bufferLength,
     Std_ReturnType returnValue,
     someStruct biDirectionalParam,
     uint16 outputParam1,
     uint32 outputParam2)
```

This function will serialize the `TransactionHandle`, the `returnValue` and all IN-OUT/OUT parameters for the response into the following format:

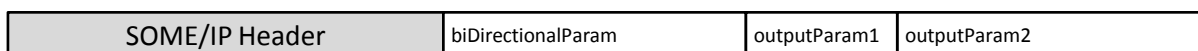

**Figure C.2: Example for serialized data of the Client/Server Response**

The SOME/IP Header contains the `TransactionHandle` and `returnValue` (see [\[SWS\\_SomeIpXf\\_00025\]](#), [\[SWS\\_SomeIpXf\\_00026\]](#) and [\[SWS\\_SomeIpXf\\_00115\]](#)).